

Carbure Monobloc

Solid Carbide

Hartmetall

Metal Duro



z = 1

Standard / Regular / Standard / Estandar

Rainurage / Slotting / Langlochfräser / Ranurado

8 23297 1

HM Carb



Perfor norm

z = 1

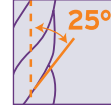

Applications
Anwendungen
Aplicaciones



Vf, Vc, fz
p. 144

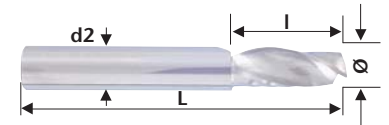

Ø mm	d2	L	l	Ø mm	d2	L	l	Ø mm	d2	L	l	Ø mm	d2	L	l
2	2	38	10	3	3	38	12	5	5	50	16	8	8	63	22
2,5	3	38	12	4	4	50	15	6	6	57	18	10	10	72	30

OUTILS SPÉCIAUX

Special tools
Sonderwerkzeuge
Fresas especiales

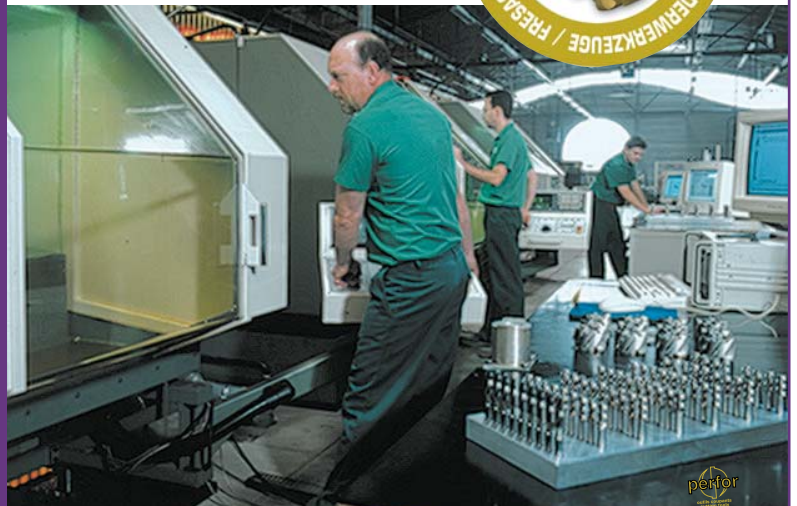
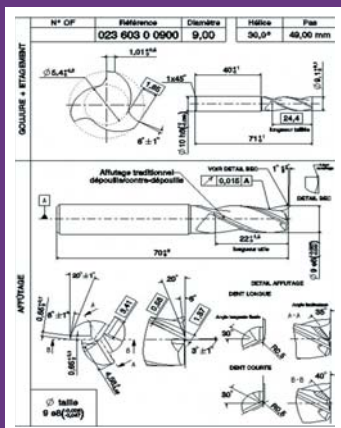

Tél : +33 0(4) 79 89 59 50 - Fax : +33 0(4) 79 89 59 51

Carbure Monobloc

Solid Carbide

Hartmetall

Metal Duro



z = 2

Standard / Regular / Standard / Estandar

Rainurage / Slotting / Langlochfräser / Ranurado

8 23613 1

HM Carb



Perfor norm

z = 2

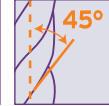

e8



Applications
Anwendungen
Aplicaciones



AL CUT 23614 p. 23



new
nouveau

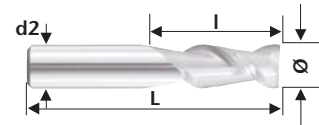

Ø mm	d2	L	l	Ø mm	d2	L	l	Ø mm	d2	L	l	Ø mm	d2	L	l
1	3	39	3	4	4	51	14	9	10	70	22	18	18	102	35
1,5	3	39	5	5	5	51	16	10	10	70	22	20	20	102	38
2	3	39	7	6	6	64	19	12	12	76	25	22	22	102	38
2,5	3	39	7	7	8	64	19	14	14	89	30	25	25	102	38
3	3	39	9	8	8	64	21	16	16	89	32				

8 23614 1

HM Carb



Perfor norm

z = 2



e8

AL CUT

Applications
Anwendungen
Aplicaciones

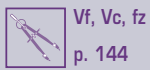

new
nouveau

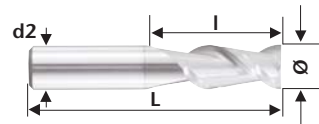

Ø mm	d2	L	l	Ø mm	d2	L	l	Ø mm	d2	L	l	Ø mm	d2	L	l
1	3	39	3	4	4	51	14	9	10	70	22	18	18	102	35
1,5	3	39	5	5	5	51	16	10	10	70	22	20	20	102	38
2	3	39	7	6	6	64	19	12	12	76	25	22	22	102	38
2,5	3	39	7	7	8	64	19	14	14	89	30	25	25	102	38
3	3	39	9	8	8	64	21	16	16	89	32				

? OUTILS SPÉCIAUX - SPECIAL TOOLS
Autre dimension / Revêtement / Application ?
Other dimension / Coating / Application ?
→ CONSULTEZ-NOUS / CONSULT US
Tél : +33 (0)4 79 89 59 50 - Fax : +33 (0)4 79 89 59 51



Carbure Monobloc

Solid Carbide

Hartmetall

Metal Duro



z = 2

Standard / Regular / Standard / Estandar

Rainurage / Slotting / Langlochfräser / Ranurado

8 **23602** 1

HM Carb



Perfor norm

z = 2

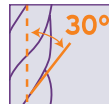

e8



Applications
Anwendungen
Aplicaciones



HARD CUT 23615 p. 24

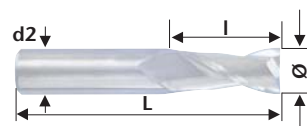
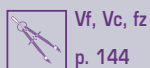

Ø mm	d2	L	l	Ø mm	d2	L	l	Ø mm	d2	L	l	Ø mm	d2	L	l
1	3	39	3	4	4	51	14	9	10	70	22	18	18	102	35
1,5	3	39	5	4,5	5	51	14	10	10	70	22	20	20	102	38
2	3	39	7	5	5	51	16	11	11	70	25	22	22	102	38
2,5	3	39	7	6	6	64	19	12	12	76	25	25	25	102	38
3	3	39	9	7	8	64	19	14	14	89	30				
3,5	4	51	12	8	8	64	21	16	16	89	32				

8 **23615** 1

HM Carb



Perfor norm

z = 2

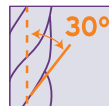

e8

HARD CUT

Applications
Anwendungen
Aplicaciones



new
nouveau

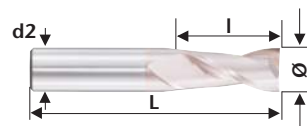

Ø mm	d2	L	l	Ø mm	d2	L	l	Ø mm	d2	L	l	Ø mm	d2	L	l
1	3	39	3	4	4	51	14	9	10	70	22	18	18	102	35
1,5	3	39	5	4,5	5	51	14	10	10	70	22	20	20	102	38
2	3	39	7	5	5	51	16	11	11	70	25	22	22	102	38
2,5	3	39	7	6	6	64	19	12	12	76	25	25	25	102	38
3	3	39	9	7	8	64	19	14	14	89	30				
3,5	4	51	12	8	8	64	21	16	16	89	32				

? OUTILS SPÉCIAUX - SPECIAL TOOLS
Autre dimension / Revêtement / Application ?
Other dimension / Coating / Application ?
→ **CONSULTEZ-NOUS / CONSULT US**
Tél : +33 (0)4 79 89 59 50 - Fax : +33 (0)4 79 89 59 51



Carbure Monobloc

Solid Carbide

Hartmetall

Metal Duro



z = 2

Standard / Regular / Standard / Estandar

Rainurage / Slotting / Langlochfräser / Ranurado

8 23672 1

HM Carb

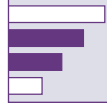

DiN 6527 K/L

z = 2



h10



Applications
Anwendungen
Aplicaciones



Vf, Vc, fz
p. 144

Méplat
Weldon Flat

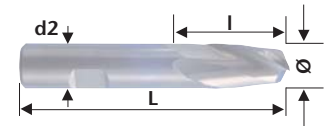

Ø mm	d2	L	l	Ø mm	d2	L	l	Ø mm	d2	L	l	Ø mm	d2	L	l
3	6	50	4	6	6	54	7	12	12	73	12	18	18	84	18
3	6	57	7	6	6	57	10	12	12	83	22	18	18	92	26
4	6	54	5	8	8	58	9	14	14	75	14	20	20	92	20
4	6	57	8	8	8	63	16	14	14	83	22	20	20	104	32
5	6	54	6	10	10	66	11	16	16	82	16				
5	6	57	10	10	10	72	19	16	16	92	26				

8 23609 1

HM Carb



Perfor norm

z = 2

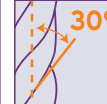

e8



Applications
Anwendungen
Aplicaciones

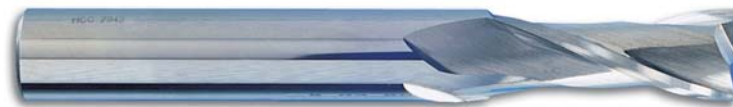

Vf, Vc, fz
p. 144

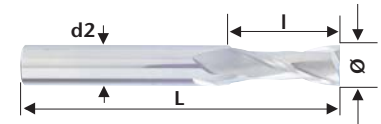

Ø mm	d2	L	l	Ø mm	d2	L	l	Ø mm	d2	L	l	Ø mm	d2	L	l
3	6	60	9	8	8	90	20	14	16	120	35	20	20	130	45
4	6	70	12	10	10	100	25	16	16	120	40				
6	6	80	15	12	12	110	30	18	18	130	40				

OUTILS SPÉCIAUX - SPECIAL TOOLS
Autre dimension / Revêtement / Application ?
Other dimension / Coating / Application ?
→ **CONSULTEZ-NOUS / CONSULT US**
Tél : +33 (0)4 79 89 59 50 - Fax : +33 (0)4 79 89 59 51



Carbure Monobloc

Solid Carbide

Hartmetall

Metal Duro



z = 3

Standard / Regular / Standard / Estandar

Rainurage / Slotting / Langlochfräser / Ranurado

8 **23603** 1

HM Carb

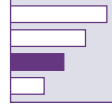

Perfor norm

z = 3

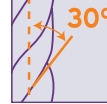

e8



Applications
Anwendungen
Aplicaciones



HARD CUT 23616 p. 26



Vf, Vc, fz
p. 144

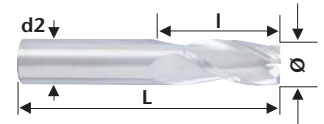

Ø mm	d2	L	l	Ø mm	d2	L	l	Ø mm	d2	L	l	Ø mm	d2	L	l
1	3	39	3	4	4	51	14	9	10	70	22	18	18	102	35
1,5	3	39	5	4,5	5	51	14	10	10	70	22	20	20	102	38
2	3	39	7	5	5	51	16	11	11	70	25	22	22	102	38
2,5	3	39	7	6	6	64	19	12	12	76	25	25	25	102	38
3	3	39	9	7	8	64	19	14	14	89	30				
3,5	4	51	12	8	8	64	21	16	16	89	32				

8 **23616** 1

HM Carb



Perfor norm

z = 3



e8

HARD CUT

Applications
Anwendungen
Aplicaciones



new
nouveau



Vf, Vc, fz
p. 144

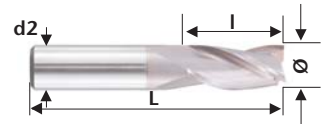

Ø mm	d2	L	l	Ø mm	d2	L	l	Ø mm	d2	L	l	Ø mm	d2	L	l
1	3	39	3	4	4	51	14	9	10	70	22	18	18	102	35
1,5	3	39	5	4,5	5	51	14	10	10	70	22	20	20	102	38
2	3	39	7	5	5	51	16	11	11	70	25	22	22	102	38
2,5	3	39	7	6	6	64	19	12	12	76	25	25	25	102	38
3	3	39	9	7	8	64	19	14	14	89	30				
3,5	4	51	12	8	8	64	21	16	16	89	32				

? OUTILS SPÉCIAUX - SPECIAL TOOLS
Autre dimension / Revêtement / Application ?
Other dimension / Coating / Application ?
→ **CONSULTEZ-NOUS / CONSULT US**
Tél : +33 (0)4 79 89 59 50 - Fax : +33 (0)4 79 89 59 51

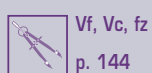
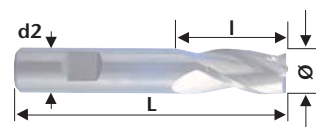

Carbure Monobloc**Solid Carbide****Hartmetall****Metal Duro****z = 3****Standard / Regular / Standard / Estandar****Rainurage / Slotting / Langlochfräser / Ranurado****8 23673 1****HM Carb****DiN 6527 K/L****z = 3****h10**
**Applications
Anwendungen
Aplicaciones**

**Méplat
Weldon Flat**

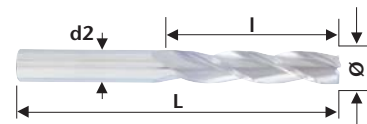
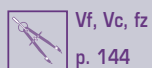
Ø mm	d2	L	l	Ø mm	d2	L	l	Ø mm	d2	L	l	Ø mm	d2	L	l
3	6	50	4	6	6	54	7	12	12	73	12	18	18	84	18
3	6	57	7	6	6	57	10	12	12	83	22	18	18	92	26
4	6	54	5	8	8	58	9	14	14	75	14	20	20	92	20
4	6	57	8	8	8	63	16	14	14	83	22	20	20	104	32
5	6	54	6	10	10	66	11	16	16	82	16				
5	6	57	10	10	10	72	19	16	16	92	26				

8 23610 1**HM Carb****Perfor norm****z = 3****h9**
**Applications
Anwendungen
Aplicaciones**

Ø mm	d2	L	l	Ø mm	d2	L	l	Ø mm	d2	L	l	Ø mm	d2	L	l
3	3	75	25	8	8	75	25	14	14	150	75	25	25	150	75
4	4	75	25	10	10	100	38	16	16	150	75				
5	5	75	25	12	12	100	50	18	18	150	75				
6	6	75	25	12	12	150	75	20	20	150	75				

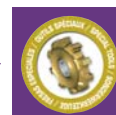
OUTILS SPÉCIAUX - SPECIAL TOOLS
 Autre dimension / Revêtement / Application ?
 Other dimension / Coating / Application ?
 → **CONSULTEZ-NOUS / CONSULT US**
 Tél : +33 (0)4 79 89 59 50 - Fax : +33 (0)4 79 89 59 51



Carbure Monobloc

Solid Carbide

Hartmetall

Metal Duro



z = 4

Standard / Regular / Standard / Estandar

Finition, fraisage combiné / Multi-purpose milling & finishing / Umfangsbearbeitung / Acabadofresado

8 23604 1

HM Carb



Perfor norm

z = 4

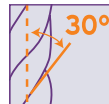

h9



Applications
Anwendungen
Aplicaciones



HARD CUT 23617 p. 28



Vf, Vc, fz
p. 144

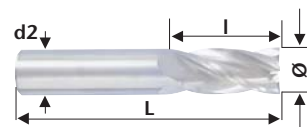
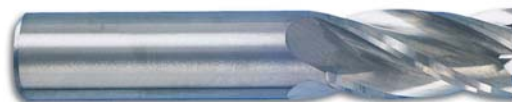

Ø mm	d2	L	l	Ø mm	d2	L	l	Ø mm	d2	L	l	Ø mm	d2	L	l
1	3	39	3	4	4	51	14	9	10	70	22	18	18	102	35
1,5	3	39	5	4,5	5	51	14	10	10	70	22	20	20	102	38
2	3	39	7	5	5	51	16	11	11	70	25	22	22	102	38
2,5	3	39	7	6	6	64	19	12	12	76	25	25	25	102	38
3	3	39	9	7	8	64	19	14	14	89	30				
3,5	4	51	12	8	8	64	21	16	16	89	32				

8 23617 1

HM Carb



Perfor norm

z = 4

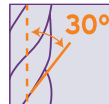

h9

HARD CUT

Applications
Anwendungen
Aplicaciones



**new
nouveau**



Vf, Vc, fz
p. 144

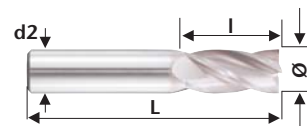

Ø mm	d2	L	l	Ø mm	d2	L	l	Ø mm	d2	L	l	Ø mm	d2	L	l
1	3	39	3	4	4	51	14	9	10	70	22	18	18	102	35
1,5	3	39	5	4,5	5	51	14	10	10	70	22	20	20	102	38
2	3	39	7	5	5	51	16	11	11	70	25	22	22	102	38
2,5	3	39	7	6	6	64	19	12	12	76	25	25	25	102	38
3	3	39	9	7	8	64	19	14	14	89	30				
3,5	4	51	12	8	8	64	21	16	16	89	32				

? OUTILS SPÉCIAUX - SPECIAL TOOLS
Autre dimension / Revêtement / Application ?
Other dimension / Coating / Application ?
→ **CONSULTEZ-NOUS / CONSULT US**
Tél : +33 (0)4 79 89 59 50 - Fax : +33 (0)4 79 89 59 51



Carbure Monobloc

Solid Carbide

Hartmetall

Metal Duro



z = 4

Standard / Regular / Standard / Estandar

Finition, fraisage combiné / Multi-purpose milling & finishing / Umfangsbearbeitung / Acabadofresado

8 23674 1

HM Carb



DiN 6527 K/L

z = 4



h10



Applications
Anwendungen
Aplicaciones

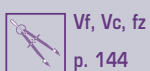
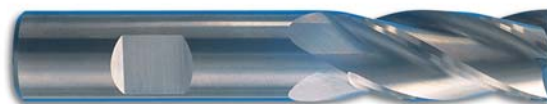

Méplat
Weldon Flat

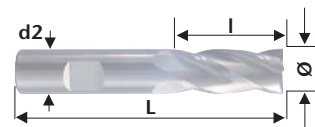

Ø mm	d2	L	l	Ø mm	d2	L	l	Ø mm	d2	L	l	Ø mm	d2	L	l
3	6	50	5	6	6	54	10	12	12	73	16	18	18	84	24
3	6	57	8	6	6	57	13	12	12	83	26	18	18	92	32
4	6	54	8	8	8	58	12	14	14	75	18	20	20	92	26
4	6	57	11	8	8	63	19	14	14	83	26	20	20	104	38
5	6	54	9	10	10	66	14	16	16	82	22				
5	6	57	13	10	10	72	22	16	16	92	32				

Ebauche / Roughing / Schruppfräser / Desbaste

8 23605 1

HM Carb



Perfor norm

z = 4

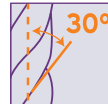

TYP HR



Applications
Anwendungen
Aplicaciones

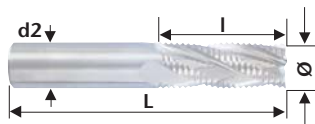
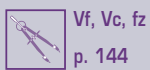

Ø mm	d2	L	l	Ø mm	d2	L	l	Ø mm	d2	L	l	Ø mm	d2	L	l
3	3	39	14	6	6	64	19	12	12	76	25	18	18	102	35
4	4	51	16	8	8	64	21	14	14	89	30	20	20	102	38
5	5	51	16	10	10	70	25	16	16	89	32	25	25	102	38

? OUTILS SPÉCIAUX - SPECIAL TOOLS
Autre dimension / Revêtement / Application ?
Other dimension / Coating / Application ?
→ CONSULTEZ-NOUS / CONSULT US
Tél : +33 (0)4 79 89 59 50 - Fax : +33 (0)4 79 89 59 51



Carbure Monobloc

Solid Carbide

Hartmetall

Metal Duro



z = 2

Standard / Regular / Standard / Estandar

Bout hémisphérique / Ball nosed / Runder Stirn / Punta esférica

8 **23606** 1

HM Carb



Perfor norm

z = 2

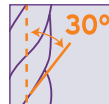

e8



Applications
Anwendungen
Aplicaciones



HARD CUT 23618 p. 30

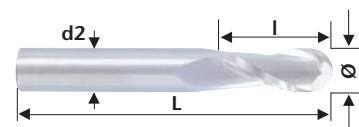
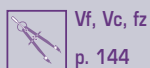

Ø mm	d2	L	l	Ø mm	d2	L	l	Ø mm	d2	L	l	Ø mm	d2	L	l
1	3	39	3	4	4	51	14	9	10	70	22	18	18	102	35
1,5	3	39	5	4,5	5	51	14	10	10	70	22	20	20	102	38
2	3	39	7	5	5	51	16	11	11	70	25	22	22	102	38
2,5	3	39	7	6	6	64	19	12	12	76	25	25	25	102	38
3	3	39	9	7	8	64	19	14	14	89	30				
3,5	4	51	12	8	8	64	21	16	16	89	32				

8 **23618** 1

HM Carb



Perfor norm

z = 2

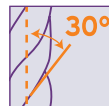

e8

HARD CUT

Applications
Anwendungen
Aplicaciones



new
nouveau

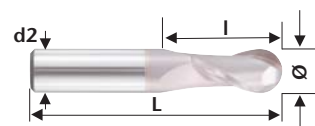
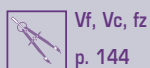

Ø mm	d2	L	l	Ø mm	d2	L	l	Ø mm	d2	L	l	Ø mm	d2	L	l
1	3	39	3	4	4	51	14	9	10	70	22	18	18	102	35
1,5	3	39	5	4,5	5	51	14	10	10	70	22	20	20	102	38
2	3	39	7	5	5	51	16	11	11	70	25	22	22	102	38
2,5	3	39	7	6	6	64	19	12	12	76	25	25	25	102	38
3	3	39	9	7	8	64	19	14	14	89	30				
3,5	4	51	12	8	8	64	21	16	16	89	32				

? OUTILS SPÉCIAUX - SPECIAL TOOLS
Autre dimension / Revêtement / Application ?
Other dimension / Coating / Application ?
→ **CONSULTEZ-NOUS / CONSULT US**
Tél : +33 (0)4 79 89 59 50 - Fax : +33 (0)4 79 89 59 51



Carbure
Monobloc

Solid Carbide

Hartmetall

Metal Duro



z = 2

Standard / Regular / Standard / Estandar

Bout hémisphérique / Ball nosed / Runder Stirn / Punta esférica

8 **23676** 1

HM
Carb

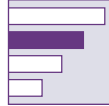

DiN
6527
L

z = 2

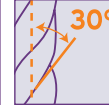

h10



Applications
Anwendungen
Aplicaciones



Vf, Vc, fz
p. 144

Méplat
Weldon Flat

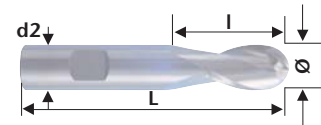

Ø mm	d2	L	I	Ø mm	d2	L	I	Ø mm	d2	L	I	Ø mm	d2	L	I
3	6	57	7	6	6	57	10	12	12	83	22	18	18	92	26
4	6	57	8	8	8	63	16	14	14	83	22	20	20	104	32
5	6	57	10	10	10	72	19	16	16	92	26				

8 **23608** 1

HM
Carb



Perfor
norm

z = 2

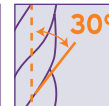

e8



Applications
Anwendungen
Aplicaciones

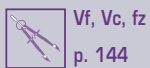

Vf, Vc, fz
p. 144

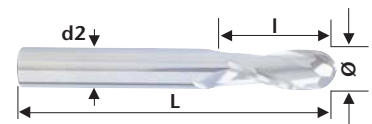

Ø mm	d2	L	I	Ø mm	d2	L	I	Ø mm	d2	L	I	Ø mm	d2	L	I
3	6	60	9	8	8	90	20	14	16	120	35	20	20	130	45
4	6	70	12	10	10	100	25	16	16	120	40				
6	6	80	15	12	12	110	30	18	20	130	40				

? **OUTILS SPÉCIAUX - SPECIAL TOOLS**
Autre dimension / Revêtement / Application ?
Other dimension / Coating / Application ?
→ **CONSULTEZ-NOUS / CONSULT US**
Tél : +33 (0)4 79 89 59 50 - Fax : +33 (0)4 79 89 59 51



Carbure
Monobloc

Solid Carbide

Hartmetall

Metal Duro



z = 3

Standard / Regular / Standard / Estandar

Bout hémisphérique / Ball nosed / Runder Stirn / Punta esférica

8 23675 1

HM
Carb



DiN
6527
L

z = 3



h10

Applications
Anwendungen
Aplicaciones

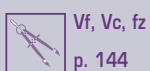
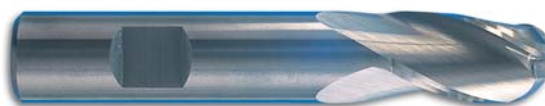

Vf, Vc, fz
p. 144

Méplat
Weldon Flat

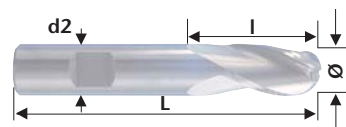

Ø mm	d2	L	l	Ø mm	d2	L	l	Ø mm	d2	L	l	Ø mm	d2	L	l
3	6	57	7	6	6	57	10	12	12	83	22	18	18	92	26
4	6	57	8	8	8	63	16	14	14	83	22	20	20	104	32
5	6	57	10	10	10	72	19	16	16	92	26				

OUTILS SPÉCIAUX

- Revêtements sur demande
- Coatings on request
- Beschichtungen auf Anfrage
- Recubrimientos bajo pedido



Tél : +33 0(4) 79 89 59 50
Fax : +33 0(4) 79 89 59 51

Special tools
Sonderwerkzeuge
Fresas especiales



AL CUT HARD CUT HIGH CUT INO CUT SLIDE CUT TiAlN TiN ULTRA CUT CrC CrN TiCN Xtreme ...

Carbure Monobloc

Solid Carbide

Hartmetall

Metal Duro



z = 4

Standard / Regular / Standard / Estandar

Bout hémisphérique / Ball nosed / Runder Stirn / Punta esférica

8 23607 1

HM Carb



Perfor norm

z = 4



h9



Applications
Anwendungen
Aplicaciones



HARD CUT 23619 p. 34

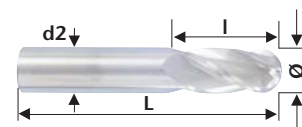
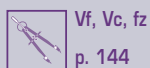

Ø mm	d2	L	l	Ø mm	d2	L	l	Ø mm	d2	L	l	Ø mm	d2	L	l
1	3	39	3	4	4	51	14	9	10	70	22	18	18	102	35
1,5	3	39	5	4,5	5	51	16	10	10	70	22	20	20	102	38
2	3	39	7	5	5	51	16	11	11	70	25	22	22	102	38
2,5	3	39	7	6	6	64	19	12	12	76	25	25	25	102	38
3	3	39	9	7	8	64	19	14	14	89	30				
3,5	4	51	12	8	8	64	21	16	16	89	32				

8 23619 1

HM Carb



Perfor norm

z = 4

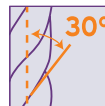

h9



Applications
Anwendungen
Aplicaciones



**new
nouveau**

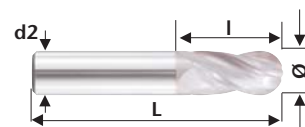

Ø mm	d2	L	l	Ø mm	d2	L	l	Ø mm	d2	L	l	Ø mm	d2	L	l
1	3	39	3	4	4	51	14	9	10	70	22	18	18	102	35
1,5	3	39	5	4,5	5	51	16	10	10	70	22	20	20	102	38
2	3	39	7	5	5	51	16	11	11	70	25	22	22	102	38
2,5	3	39	7	6	6	64	19	12	12	76	25	25	25	102	38
3	3	39	9	7	8	64	19	14	14	89	30				
3,5	4	51	12	8	8	64	21	16	16	89	32				

? OUTILS SPÉCIAUX - SPECIAL TOOLS
Autre dimension / Revêtement / Application ?
Other dimension / Coating / Application ?
→ **CONSULTEZ-NOUS / CONSULT US**
Tél : +33 (0)4 79 89 59 50 - Fax : +33 (0)4 79 89 59 51



Carbure
Monobloc

Solid Carbide

Hartmetall

Metal Duro



z = 4

Standard / Regular / Standard / Estandar

Bout hémisphérique / Ball nosed / Runder Stirn / Punta esférica

8 23677 1

HM
Carb



DiN
6527
L

z = 4

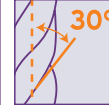

h10



Applications
Anwendungen
Aplicaciones

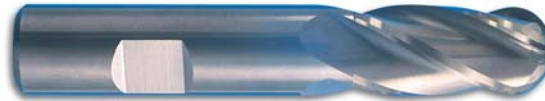

Vf, Vc, fz
p. 144

Méplat
Weldon Flat

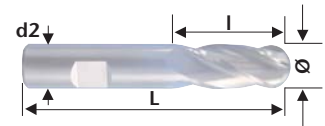

Ø mm	d2	L	l	Ø mm	d2	L	l	Ø mm	d2	L	l	Ø mm	d2	L	l
3	6	57	8	6	6	57	13	12	12	83	26	18	18	92	32
4	6	57	11	8	8	63	19	14	14	83	26	20	20	104	38
5	6	57	13	10	10	72	22	16	16	92	32				

OUTILS SPÉCIAUX

Special tools
Sonderwerkzeuge
Fresas especiales

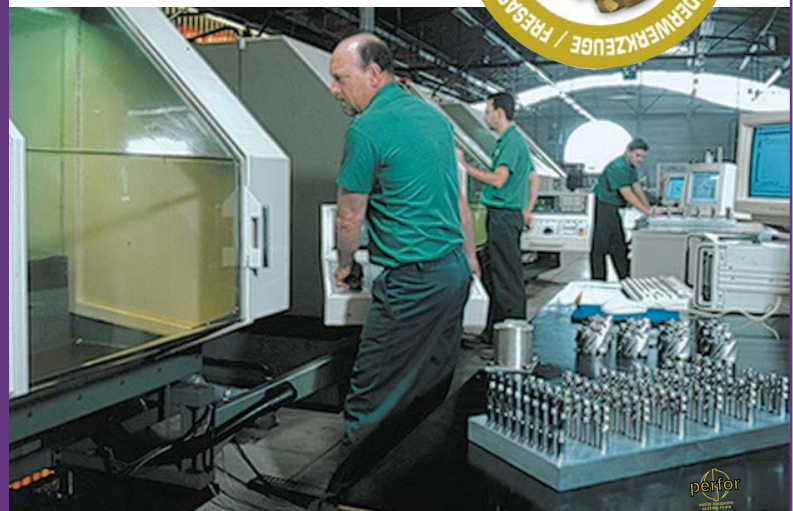
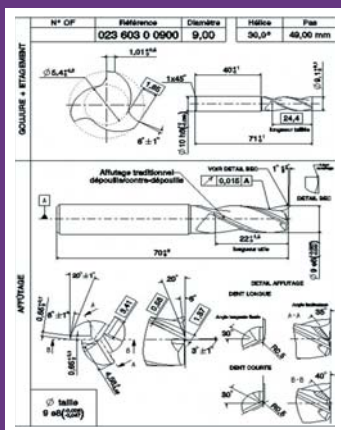

Tél : +33 0(4) 79 89 59 50 - Fax : +33 0(4) 79 89 59 51