

BLUE-MASTER
by celisa

AVELLANADORES



AVELLANADORES PARA TUBO Y CHAPA

REFERENCIA	MATERIAL	TIPO	ACABADOS	APLICACIÓN	PÁGINA
AV30	HSS		BRILLANTE TiN	 	104
AVC30	HSS-Co		BRILLANTE TiN	 	104

BROCAS AVELLANADORAS PARA CHAPA

AV36	HSS	CANAL HELICOIDAL	BRILLANTE TiN		105
AV33	HSS	3 Z	BRILLANTE TiN		105
AV32	HSS	1/4"	BRILLANTE TiN		105
AV31	HSS	TOPE DE PROFUNDIDAD	BRILLANTE TiN		105

BROCAS ESCALONADAS DE CANAL RECTO

AV40	HSS	CANAL RECTO	BRILLANTE TiN		106
AVC40	HSS-Co	CANAL RECTO	DORADO TiN		107





BROCAS ESCALONADAS DE CANAL HELICOIDAL

AV42	HSS	CANAL HELICOIDAL	BRILLANTE TiN		107
AV41	HSS	1/4"	BRILLANTE TiN		108
AVC41	HSS	SERIE CORTA Máx. espesor 2 mm.	BRILLANTE TiN		108
AV45	HSS	ATORNILLAMIENTOS MÉTRICOS DE CABLE	BRILLANTE TiN		108
AV43	HSS	ESCALONADA CON 3 CORTES	BRILLANTE TiN		108

AVELLANADORES DE 3 CANALES

REFERENCIA	MATERIAL	NORMA	ÁNGULO	ACABADO	APLICACIÓN	PÁGINA
AV6	HSS	DIN 335C	90°		USO GENERAL	109
AV7	HSS-Co	DIN 335C	90°		USO GENERAL	109
AV16	HSS	DIN 335C	90°	TiN	USO GENERAL	109





AVELLANADORES DE 3 CANALES

REFERENCIA	MATERIAL	NORMA	ÁNGULO	ACABADO	APLICACIÓN	PÁGINA
AV37 	HSS	DIN 335C	90°	TiAIN	USO GENERAL	109
AV19 	HSS	DIN 335C	90°		AI	109
AV6MD 	MD	DIN 335C	90°		MATERIAL DURO	109
AV8 	HSS	DIN 334C	60°			109
AV9 	HSS	NORMA CELESA	75°			109
AV10 	HSS	NORMA CELESA	120°			109
AV15 	HSS	DIN 335C	90°			110

AVELLANADORES MULTICORTE

AV12 	HSS	DIN 334A	60°			110
AV11 	HSS	DIN 335A	90°			110
AV13 	MD	DIN 347A	120°			110

AVELLANADORES PARA DESBARBAR CON AGUJERO

AV1 	HSS	NORMA CELESA	90°			111
AV1T 	HSS	NORMA CELESA	90°	TiN		111
AV2 	HSS-Co	NORMA CELESA	90°			111
AV2T 	HSS-Co	NORMA CELESA	90°	TiN		111
AV1-60 	HSS	NORMA CELESA	60°			111

AVELLANADORES EXTERNOS DE 3 CORTES

AVX 	HSS	NORMA CELESA	90°			111
AVX-60 	HSS	NORMA CELESA	60°			111

AVELLANADORES CON MANGO CÓNICO CON 3 CORTES Y MULTICORTE

REFERENCIA	MATERIAL	NORMA	ÁNGULO	AJUSTE	TIPO	PÁGINA
AV17	HSS	DIN 335D	90°		3 CORTES	112
AV17MD	MD	DIN 335D	90°		3 CORTES	112
AV23	HSS	DIN 334B	60°		MULTICORTE	112
AV18	HSS	DIN 335B	90°		MULTICORTE	112
AV24	HSS	DIN 347B	120°		MULTICORTE	112

AVELLANADORES DE 1 CANAL CON MANGO CILÍNDRICO Y MANGO CÓNICO

AV27	HSS	NORMA CELESA	90°		MANGO CILÍNDRICO	113
AV29	HSS	NORMA CELESA	60°		MANGO CILÍNDRICO	113
AV34	HSS	NORMA CELESA	90°		MANGO CÓNICO	113
AV28	HSS	NORMA CELESA	60°		MANGO CÓNICO	113

AVELLANADORES PARA ASIENTOS DE TORNILLOS "ALLEN"

AV2	HSS	DIN 373		FINO	MANGO CILÍNDRICO	114
AV2M	HSS	DIN 373		MEDIO	MANGO CILÍNDRICO	114
AV2G	HSS	DIN 373		GRUESO	MANGO CILÍNDRICO	114
AV3	HSS	DIN 1866		FINO	CABEZA CÓNICA+GUÍA	114
AV5	HSS	DIN 375		FINO	MANGO CÓNICO	115
AV5M	HSS	DIN 375		MEDIO	MANGO CÓNICO	115
AV5G	HSS	DIN 375		GRUESO	MANGO CÓNICO	115

AVELLANADORES CON ELEMENTOS INTERCAMBIABLES PARA ASIENTOS DE TORNILLOS ALLEN Y CÓNICOS

AGP BGP CGP		SERIE A/B/C			GUÍA	117
-------------------	--	-------------	--	--	------	-----

AVELLANADORES CON ELEMENTOS INTERCAMBIABLES PARA ASIENTOS DE TORNILLOS ALLEN Y CÓNICOS

REFERENCIA	MATERIAL	NORMA	ÁNGULO	TIPO	PÁGINA
APAV BPAV CPAV	HSS	SERIE A/B/C		PORTA	117
APAVMD BPAVMD CPAVMD	MD	SERIE A/B/C		PORTA	117
APAVPQ BPAVPQ CPAVPQ	PMD	SERIE A/B/C		PLAQUITA INTERCAMBIABLE	117
AVC BVC CVC	HSS	SERIE A/B/C	90°	AVELLANADOR	117
ABP BBP CBP	HSS	SERIE A/B/C		BROCA	117
APH BPH CPH				ADAPTADORES	117
PPQ	MD			PLAQUITA DE REPUESTO	117

AMPLIA GAMA DE ESTUCHES METÁLICOS DE AVELLANADORES



120

REBARBADORES DE PRECISIÓN EN BLISTER

REFERENCIA		PÁGINA
GRUPO B		CONJUNTO Ref. JRB1 Y PIEZAS SUELTAS 123
GRUPO C		CONJUNTO Ref. JRB2 Y PIEZAS SUELTAS 123
GRUPO D		CONJUNTO Ref. JRB3 Y PIEZAS SUELTAS 123
GRUPO E		CONJUNTO Ref. JRB4 Y PIEZAS SUELTAS 123
GRUPO F		CONJUNTO Ref. JRB5 Y PIEZAS SUELTAS 123
GRUPO A1		CONJUNTO Ref. JRB6 Y PIEZAS SUELTAS 123
GRUPO A2		CONJUNTO Ref. JRB7 Y PIEZAS SUELTAS 123

BROCA AVELLANADORA PARA TUBO Y CHAPA HSS y HSS-Co

Avellanadores

Rosa

HSS

Ref. **AV30**



	D _{min} mm.	D _{max} mm.	D ₂ mm.	L ₁ mm.	AV30	
					HSS €	TiN €
AV30BM0B	3,0	14,0	6,0	58	16,14	32,00
AV30BM8B	3,0	22,5	8,0	85	44,64	80,24
AV30BM5B	3,0	31,0	10,0	102	72,06	107,12
AV30BM9B	5,0	25,4	10,0	87	51,24	97,09
AV30BM1B	6,0	20,0	8,0	63	22,57	45,41
AV30BM2B	16,0	30,0	10,0	79	45,94	80,07
AV30BM3B	26,0	40,0	13,0	86	97,14	146,70
AV30BM4	36,0	50,0	13,0	89	143,07	219,24
AV30BM6	40,0	61,0	13,0	98	237,02	355,98

* Las referencias acabadas en B, se suministran en blister.

HSS-Co

Ref. **AVC30**



	D _{min} mm.	D _{max} mm.	D ₂ mm.	L ₁ mm.	AVC30	
					HSS-Co €	TiN €
AVC30BM0B	3,0	14,0	6,0	58	28,66	38,11
AVC30BM1B	6,0	20,0	8,0	63	38,00	58,75
AVC30BM2B	16,0	30,0	10,0	79	62,70	85,11
AVC30BM3B	26,0	40,0	13,0	86	163,14	179,23

BROCAS AVELLANADORAS PARA CHAPA HSS

HSS

CANAL HELICOIDAL

	D _{min} mm.	D _{max} mm.	D ₂ mm.	L ₁ mm.	AV36	
					HSS	TiN
					€	€
AV36BM0B	3,0	14,0	6,0	60	23,80	39,97
AV36BM1B	5,0	20,0	8,0	76	31,10	53,51
AV36BM2B	5,0	31,0	10,0	105	63,77	98,16



Ref. **AV36**

3 CORTES

	D _{min} mm.	D _{max} mm.	D ₂ mm.	L ₁ mm.	AV33	
					HSS	TiN
					€	€
AV33BM0B	3,0	14,0	6,0	58	36,70	50,38
AV33BM1B	5,0	20,0	8,0	71	44,04	61,23
AV33BM2B	16,0	30,5	9,0	76	76,87	105,05



Ref. **AV33**

MANGO HEXAGONAL 1/4"

	D _{min} mm.	D _{max} mm.		L ₁ mm.	AV32	
					HSS	TiN
					€	€
AV32BM1B	5,0	20,0	1/4"	78	36,80	59,79



Ref. **AV32**

TOPE DE PROFUNDIDAD

	D _{min} mm.	D _{max} mm.	D ₂ mm.	L ₁ mm.	AV31	
					HSS	TiN
					€	€
AV31BM0B	3,0	7,8	6,0	48	23,64	37,50
AV31BM1B	3,0	10,2	6,0	52	31,03	51,02
AV31BM2B	3,0	11,8	6,0	56	34,54	63,99



Ref. **AV31**

BROCAS ESCALONADAS DE CANAL RECTO HSS

HSS

Ref. **AV40**

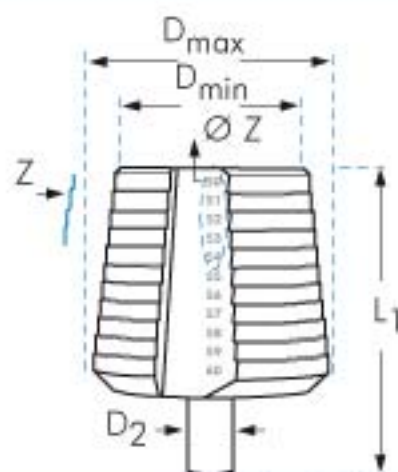
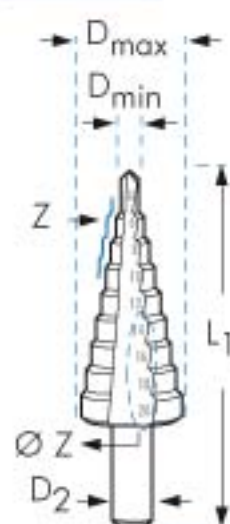

BM1 BM2 BM3 BM4 BM5

Ref. **AV40BM25 / 26 / 27 / 28 / 29**

							AV40	
							HSS	TiN
	D_{min} mm.	D_{max} mm.	D_2 mm.	L_1 mm.	Z	$\varnothing Z$ mm. menor - mayor	€	€
AV40BM1B	4,0	12,0	6,0	56	5	4-6-8-10-12	31,19	44,26
AV40BM2B	4,0	12,0	6,0	65	9	4-5-6-7-8-9-10-11-12	32,58	45,59
AV40BM3B	4,0	20,0	8,0	69	9	4-6-8-10-12-14-16-18-20	44,08	64,64
AV40BM4B	4,0	30,0	10,0	96	14	4-6-8-10-12-14-16-18-20-22-24-26-28-30	85,73	118,78
AV40BM14	4,0	39,0	10,0	107	13	4-6-9-12-15-18-21-24-27-30-33-36-39	147,22	242,92
AV40BM16B	5,0	28,0	10,0	69	7	5-8,8-11,8-15,3-19-24,5-28	68,29	112,69
AV40BM11B	6,0	25,0	10,0	65	7	6-9-12-16-20-22,50-25	55,77	83,73
AV40BM10B	6,0	26,7	10,0	75	8	6-9-11,40-14-17,25-19-21,25-26,75	108,58	179,16
AV40BM17B	6,0	30,5	10,0	80	9	6-9-12,5-15,2-18,6-20,4-22,5-28,3-30,5	115,28	190,21
AV40BM12B	6,0	32,0	10,0	75	9	6-9-12-16-20-22,5-25-28,5-32	78,70	112,82
AV40BM18B	6,0	37,0	10,0	100	12	6-9-12,5-15,2-18,6-20,4-22,5-26-28,3-30,5-34-37	138,40	228,36
AV40BM5B	6,0	38,0	10,0	96	12	6-9-13-16-19-21-23-26-29-32-35-38	159,95	212,40
AV40BM13	6,0	40,0	13,0	105	16	6-11-17-23-29-30-31-32-33-34-35-36-37-38-39-40	190,62	245,58
AV40BM15B	6,5	32,5	10,0	79	9	6,50-8,50-10,50-12,50-16,50-20,50-25,50-29-32,50	91,12	133,91
AV40BM20	6,5	40,5	10,0	96	11	6,50-8,50-10,50-12,50-16,50-20,50-25,50-29-32,50-36,50-40,50	142,86	235,73
AV40BM21B	7,0+10,0	20,0	10,0	80	12	7-10-11-12-13-14-15-16-17-18-19-20	57,16	94,32
AV40BM22B	10,0+20,0	30,0	13,0	83	12	10-20-21-22-23-24-25-26-27-28-29-30	89,21	147,19
AV40BM25B	12,0	20,0	8,0	66	9	12-13-14-15-16-17-18-19-20	59,52	79,11
AV40BM26B	20,0	30,0	10,0	78	11	20-21-22-23-24-25-26-27-28-29-30	86,41	123,91
AV40BM27	30,0	40,0	10,0	78	11	30-31-32-33-34-35-36-37-38-39-40	118,11	163,92
AV40BM28	40,0	50,0	13,0	85	11	40-41-42-43-44-45-46-47-48-49-50	195,50	275,03
AV40BM29	50,0	60,0	13,0	85	11	50-51-52-53-54-55-56-57-58-59-60	292,51	366,75
PARA PASAR TUBERÍAS ROSCA GAS								
AV40BM6B	6,0	32,0	10,0	75	8	6-9-11,20-14,50-18,20-22,30-27,90-32	81,66	117,36
PARA REMACHES CIEGOS M3 - M4 - M5 - M6 Y M7								
AV40BM7B	4,8	10,6	6,0	54	5	4,80-6,40-7,20-9,60-10,65	26,62	39,80
PARA CONDUCCIONES ELÉCTRICAS (ANTIGUA Y NUEVA NORMA)								
AV40PG21B	PG7	PG21	13,0	70	6	PG7-PG9-PG11-PG13,50-PG16-PG21	87,46	133,29
AV40PG29B	PG7	PG29	13,0	81	7	PG7-PG9-PG11-PG13,50-PG16-PG21-PG29	112,98	170,86
AV40BM8B	8,5+10,5	32,5	10,0	70	12	(8,5)-10,5-12,5-14,5-16,5-18,5-20,5-23,5-25,5-28-30,5-32,5	68,17	109,90
AV40BM9B	8,5+10,5	40,5	12,0	84	16	(8,5)-10,5-12,5-14,5-16,5-18,5-20,5-23,5-25,5-28-30,5-32,5-34,5-36,5-38,5-40,5	118,42	169,02

BROCAS ESCALONADAS DE CANALES RECTOS HSS-Co

HSS-Co

Ref. **AVC40**

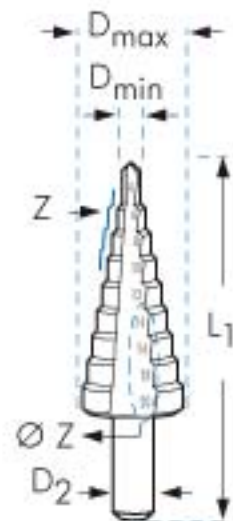

BM1 BM2 BM3 BM4 BM5



Avellanadores

Rosa

							AVC40	
	D _{min} mm.	D _{max} mm.	D ₂ mm.	L ₁ mm.	Z	Ø Z mm. menor - mayor	HSS-Co €	TiN €
AVC40BM1B	4,0	12,0	6,0	56	5	4-6-8-10-12	43,55	65,91
AVC40BM2B	4,0	12,0	6,0	65	9	4-5-6-7-8-9-10-11-12	45,99	79,59
AVC40BM3B	4,0	20,0	8,0	69	9	4-6-8-10-12-14-16-18-20	69,51	90,19
AVC40BM4B	4,0	30,0	10,0	96	14	4-6-8-10-12-14-16-18-20-22-24-26-28-30	99,99	141,37
AVC40BM18B	6,0	37,0	10,0	100	12	6-9-12,5-15,2-18,6-20,4-22,5-26-28,3-30,5-34-37	179,11	237,51

BROCAS ESCALONADAS DE CANALES HELICOIDALES HSS

HSS

Ref. **AV42**

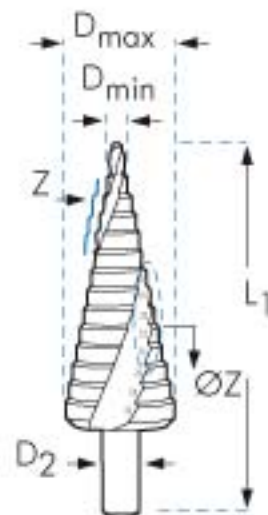

BM2 BM3 BM4



							AV42	
	D _{min} mm.	D _{max} mm.	D ₂ mm.	L ₁ mm.	Z	Ø Z mm. menor - mayor	HSS €	TiN €
AV42BM1B	4,0	12,0	6,0	56	5	4-6-8-10-12	40,27	54,39
AV42BM2B	4,0	12,0	6,0	68	9	4-5-6-7-8-9-10-11-12	41,65	56,64
AV42BM3B	4,0	20,0	8,0	69	9	4-6-8-10-12-14-16-18-20	59,10	79,19
AV42BM4B	4,0	30,0	10,0	96	14	4-6-8-10-12-14-16-18-20-22-24-26-28-30	97,67	130,96
AV42BM5B	6,0	38,0	10,0	96	12	4-6-9-12-15-18-21-24-27-30-33-36-38	169,02	224,89
AV42BM11B	6,0	25,0	10,0	65	7	6-9-12-16-20-22,5-25	68,13	92,87
AV42BM12B	6,0	32,0	10,0	75	9	6-9-12-16-20-22,5-25-28,5-32	88,86	116,89
AV42BM13	6,0	40,0	13,0	105	16	6-11-17-23-29-30-31-32-33-34-35-36-37-38-39-40	196,15	265,53
AV42BM8B	8,5 + 10,5	32,5	10,0	70	12	(8,5)10,5-12,5-14,5-16,5-18,5-20,5-23,5 25,5-28-30,5-32,5	89,68	121,54
AV42BM9B	8,5 + 10,5	40,5	12,0	84	16	(8,5)-10,5-12,5-14,5-16,5-18,5-20,5-23,5 25,5-28-30,5-32,5-34,5-36,5-38,5-40,5	141,04	179,87

BROCAS ESCALONADAS HELICOIDALES HSS

HSS

MANGO HEXAGONAL 1/4"

	D _{min} mm.	D _{max} mm.		L ₁ mm.	Z	Ø Z mm. menor - mayor	AV41	
							HSS €	TIN €
AV41BM2B	4,0	12,0	1/4"	72	9	4-5-6-7-8-9-10-11-12	63,81	82,97
AV41BM3B	4,0	20,0	1/4"	81	9	4-6-8-10-12-14-16-18-20	84,36	109,71
AV41BM4B	4,0	30,0	1/4"	105	14	4-6-8-10-12-14-16-18-20-22-24-26-28-30	99,99	126,30



Ref. AV41BM2

SERIE CORTA Máximo 2 mm. de espesor

	D _{min} mm.	D _{max} mm.	D ₂ mm.	L ₁ mm.	Z	Ø Z mm. menor - mayor	AV41C	
							HSS €	TIN €
AV41CBM2B	4,0	12,0	6,0	48	9	4-5-6-7-8-9-10-11-12	45,40	63,91
AV41CBM3B	4,0	20,0	8,0	58	9	4-6-8-10-12-14-16-18-20	56,37	82,59
AV41CBM4B	4,0	30,0	10,0	72	14	4-6-8-10-12-14-16-18-20-22-24-26-28-30	91,91	148,38



Ref. AV41CBM3

ATORNILLAMIENTOS MÉTRICOS DE CABLE

	DIN	D _{min} mm.	D _{max} mm.	D ₂ mm.	L ₁ mm.	Z	Ø Z mm. menor - mayor	AV45	
								HSS €	TIN €
AV45BMOB	60423	5,3	30,5	10,0	79	9	5,3-7-9-10,5-14,5-18,5-23,5-27-30,5	125,29	169,39
AV45BM1B	50262	6,5	32,5	10,0	79	9	6,5-8,5-10,5-12,5-16,5-20,5 25,5-29-32,5	127,42	175,81
AV45BM2B	60423	5,3	38,5	10,0	96	11	5,3-7-9-10,5-14,5-18,5-23,5-27 30,5-34,5-38,5	150,66	199,59
AV45BM3B	50262	6,5	40,5	10,0	96	11	6,5-8,5-10,5-12,5-16,5-20,5-25,5 29-32,5-36,5-40,5	152,08	199,99



Ref. AV45BM3

ESCALONADA RECTA CON 3 CORTES

	D _{min} mm.	D _{max} mm.	D ₂ mm.	L ₁ mm.	Z	Ø Z mm. menor - mayor	AV43	
							HSS €	TIN €
AV43BM1B	4,0	12,0	6,0	65	9	4-5-6-7-8-9-10-11-12	54,73	75,09
AV43BM2B	4,0	20,0	8,0	75	9	4-6-8-10-12-14-16-18-20	75,04	121,91
AV43BM3B	4,0	30,0	10,0	100	14	4-6-8-10-12-14-16-18-20-22-24-26-28-30	110,32	189,19

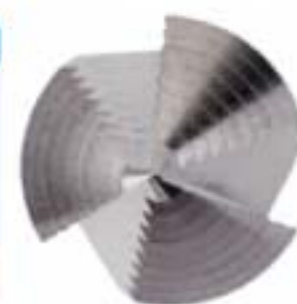

Ref. AV43BM3

AVELLANADORES DE 3 CANALES

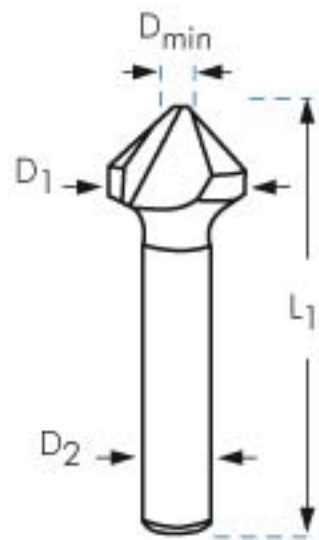

				AV6	AV7	AV16	AV37	AV19	AV6MD	AV8	AV9	AV10
MATERIAL				HSS	HSS-Co	HSS	HSS	HSS	MD	HSS	HSS	HSS
NORMA				DIN 335C	DIN 335C	DIN 335C	DIN 335C	DIN 335C	DIN 335C	DIN 334C	NORMA CELESA	NORMA CELESA
ÁNGULO DE PUNTA				90°	90°	90°	90°	90°	90°	60°	75°	120°
ACABADO						TIN	TiAIN					
APLICACIÓN				USO GENERAL	USO GENERAL	USO GENERAL	USO GENERAL	AI	MATERIAL DURO			
D ₁ mm.	D _{min} mm.	D ₂ mm.	L ₁ mm.	€	€	€	€	€	€	€	€	€
4,30	1,3	4,0	40	12,86	15,17	23,39	27,53					
5,00	1,5	4,0	40	12,86	15,17	23,39	27,53					
5,30	1,5	4,0	40	12,86	15,17	23,39	27,53		52,10			
5,80	1,5	5,0	45	9,77	11,53	20,55	25,84		53,30			
6,00	1,5	5,0	45	9,30	11,08	20,10	25,84					
6,30	1,5	5,0	45	9,14	10,88	20,10	25,84	14,97	58,21	15,15	11,66	12,41
7,00	1,8	6,0	50	12,86	15,17	26,84	34,48					
7,30	1,8	6,0	50	12,86	15,17	26,84	34,48		62,12			
8,00	2,0	6,0	50	12,86	15,32	26,84	34,48			16,65		
8,30	2,0	6,0	50	12,66	15,04	26,84	34,48	16,76	66,12		15,89	17,10
9,40	2,2	6,0	50	14,99	17,74	30,29	38,63		71,10			
10,00	2,5	6,0	50	14,99	17,74	30,29	38,63			18,16		
10,40	2,5	6,0	50	14,72	17,58	30,29	38,63	19,70	72,12		18,78	19,98
11,50	2,8	8,0	56	15,07	19,57	32,08	41,53					
12,40	2,8	8,0	56	14,81	19,35	32,08	41,53	21,56	75,21	20,13	20,74	23,92
13,40	2,9	8,0	56	16,29	21,10	33,14	42,90		81,21			
15,00	3,2	10,0	60	20,68	26,88	44,54	58,74					
16,50	3,2	10,0	60	20,34	26,51	45,74	58,74	25,75	82,36	25,75	26,03	30,27
19,00	3,5	10,0	63	30,46	39,76	55,80	71,27					
20,50	3,5	10,0	63	29,94	39,03	56,99	73,42	35,77	114,21	36,34	38,31	44,67
23,00	3,8	10,0	67	37,45	48,44	64,92	82,15					
25,00	3,8	10,0	67	37,78	49,31	65,84	83,02	50,47	186,36	50,72	48,28	56,33
28,00	4,0	12,0	71	52,76	70,41	83,69	107,42					
30,00	4,2	12,0	71	56,06	74,48	86,84	139,99					
31,00	4,2	12,0	71	58,36	74,48	90,00	150,33	69,08	210,29			
40,00	6,5	13,0	80	86,78	111,08	137,37	176,75	109,09	365,10	112,17	105,06	123,81

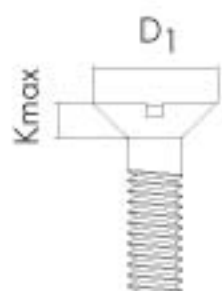

DIN 7991

DIMENSIONES TORNILLO CABEZA CÓNICA 90°

	M2	M2.5	M3	M4	M5	M6	M8	M10	M12	M14	M16	M18	M20
Kmax	1,2	1,5	1,7	2,3	2,8	3,3	4,4	5,5	6,5	7	7,5	8	8,5
D1	4	5	6	8	10	12	16	20	24	27	30	33	36

AVELLANADORES HSS

SERIE LARGA

Ref. **AV15**

HSS

DIN
335C

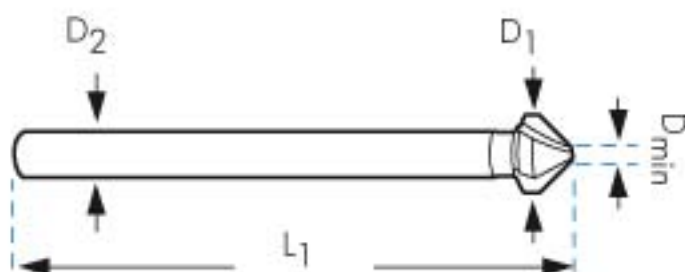

				AV15
D1 mm.	D _{min} mm.	D2 mm.	L1 mm.	€
10,40	2,5	6,0	112	45,36
12,40	2,8	8,0	112	55,30
16,50	3,2	10,0	120	66,64
20,50	3,5	10,0	124	89,33
25,00	3,8	10,0	128	107,74
31,00	4,2	12,0	133	126,20

AVELLANADORES MULTICORTE MANGO CILÍNDRICO 60°, 90° Y 120°

5Z

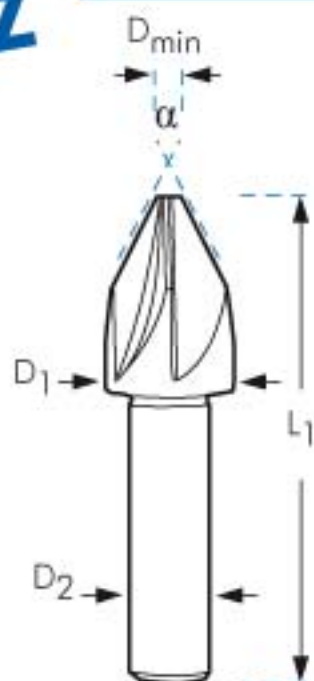

				AV12			AV11			AV13		
MATERIAL				HSS			HSS			HSS		
DIN				DIN 334A			DIN 335A			DIN 347A		
ÁNGULO DE PUNTA				60°			90°			120°		
D1 mm.	D _{min} mm.	D2 mm.	Nº Z	L1 mm.	€	L1 mm.	€	L1 mm.	€			
8,00	2,5	8,0	5	AV120800	48	12,39	AV110800	44	9,49	AV130800	44	12,39
12,50	2,8	8,0	5	AV121250	52	18,52	AV111250	48	13,90	AV131250	48	18,18
16,00	3,0	10,0	5	AV121600	60	31,08	AV111600	56	23,35	AV131600	56	30,50
20,00	3,5	10,0	5	AV122000	64	40,09	AV112000	60	30,07	AV132000	60	39,34
25,00	3,5	12,0	5	AV122500	69	56,11	AV112500	65	42,10	AV132500	65	55,06

AVELLANADORES HSS Y HSS-Co PARA DESBARBAR CON AGUJERO

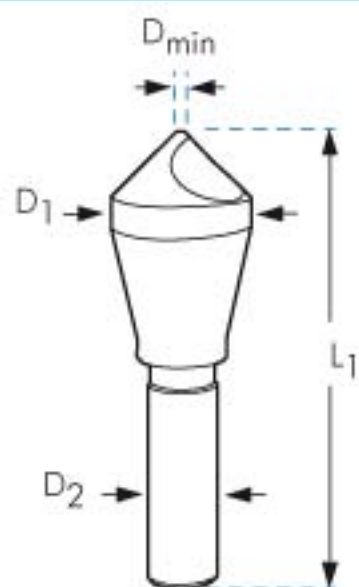

				AV1		AV1T		AV2		AV2T		AV1-60	
MATERIAL				HSS		HSS		HSS-Co		HSS-Co		HSS	
ACABADO						TiN				TiN			
ÁNGULO DE PUNTA				90°		90°		90°		90°		60°	
D ₁ mm.	D _{min} mm.	D ₂ mm.	L ₁ mm.	€	€	€	€	€	€	€	€	€	€
6,35	1,0	6,35	45	AV100	10,59	AV100T	18,86	AV200	18,36	AV200T	30,99	AV100-60	18,69
10,00	2,0	6,00	45	AV101	13,06	AV101T	19,72	AV201	18,96	AV201T	30,99	AV101-60	23,36
14,00	5,0	8,00	48	AV102	16,32	AV102T	27,72	AV202	22,08	AV202T	38,64	AV102-60	28,36
20,00	10,0	10,00	65	AV103	29,23	AV103T	49,55	AV203	39,49	AV203T	65,42	AV103-60	32,36
27,00	15,0	12,00	85	AV104	52,23	AV104T	81,48	AV204	64,33	AV204T	103,05	AV104-60	56,36
30,00	20,0	15,00	95	AV105	88,14	AV105T	154,61	AV205	102,20	AV205T	177,07	AV105-60	92,36
35,00	25,0	15,00	100	AV106	135,38	AV106T	211,72	AV206	171,23	AV206T	297,78	AV106-60	146,36
40,00	30,0	15,00	110	AV107	183,43	AV107T	310,14	AV207	197,02	AV207T	319,04	AV107-60	198,36
45,00	35,0	15,00	120	AV108	243,04	AV108T	414,05	AV208	296,09	AV208T	423,24	AV108-60	256,36
50,00	40,0	15,00	130	AV109	293,23	AV109T	503,87	AV209	394,63	AV209T	531,38	AV109-60	312,36

AVELLANADORES EXTERNOS DE 3 CORTES

3Z

Ref. AVX

HSS



Ref. AVX-60

HSS

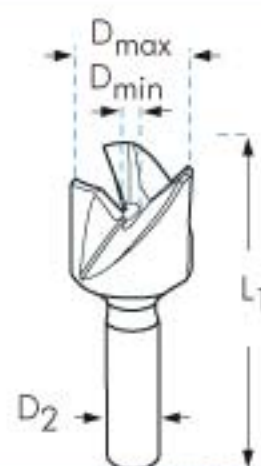
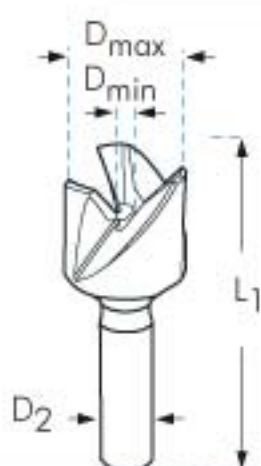

				AVX	
D _{max} mm.	D _{min} mm.	D ₂ mm.	L ₁ mm.	€	€
12,00	4,0	8,0	55	AVX1	32,38
20,00	6,0	10,0	60	AVX2	56,17
28,00	8,0	13,0	70	AVX3	79,67
40,00	10,0	13,0	100	AVX4	166,96
50,00	15,0	13,0	100	AVX5	233,27

				AVX-60	
D _{max} mm.	D _{min} mm.	D ₂ mm.	L ₁ mm.	€	€
8,00	3,0	8,0	55	AVX1-60	31,12
15,00	4,0	10,0	60	AVX2-60	61,80
28,00	10,0	13,0	80	AVX3-60	92,63

AVELLANADORES CON MANGO CÓNICO

3Z

Ref. **AV17**

DIN 335D

HSS



Ref. **AV17MD**

DIN 335D

MD

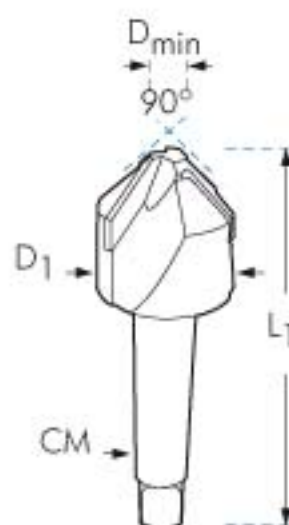
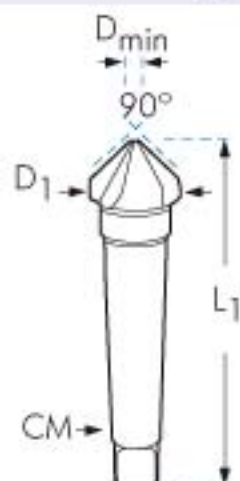

				AV17
D ₁ mm.	D _{min} mm.	L ₁ mm.	CM	€
16,50	4,0	90	1	64,13
20,50	3,5	100	2	77,06
25,00	3,8	106	2	77,85
31,00	4,2	112	2	86,66
40,00	10,0	140	3	130,85
50,00	14,0	150	3	164,71
63,00	16,0	180	4	266,31
80,00	22,0	190	4	455,66
100,00	25,0	210	4	1.173,38

				AV17MD
D ₁ mm.	D _{min} mm.	L ₁ mm.	CM	€
50,00	14,0	123	3	882,49
63,00	16,0	190	4	1.055,47
80,00	22,0	190	4	1.288,53

MULTI CORTE

Ref. **AV23**

DIN 334B



Ref. **AV18**

DIN 335B



Ref. **AV24**

DIN 347B

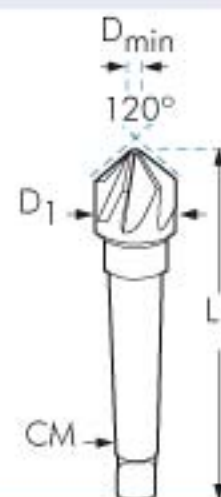
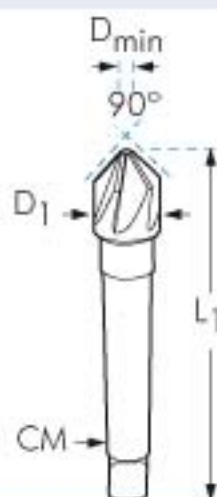
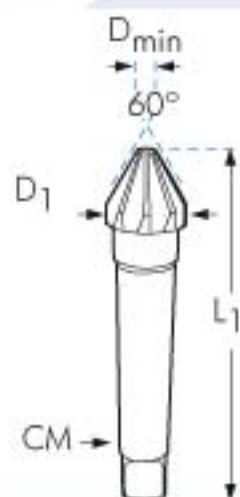

						AV23
						HSS
D ₁ mm.	D _{min} mm.	L ₁ mm.	CM	Z		€
16,00	3,2	93	1	7		46,08
20,00	4,0	116	2	7		53,93
25,00	7,0	121	2	9		59,08
31,50	9,0	124	2	9		80,79
40,00	12,5	150	3	11		151,54
50,00	16,0	153	3	13		176,74
63,00	20,0	185	4	15		270,57
80,00	25,0	196	4	17		418,16
100,00	22,0	230	4	3		1.383,53

						AV18
						HSS
D ₁ mm.	D _{min} mm.	L ₁ mm.	CM	Z		€
16,00	3,2	93	1	7		46,99
20,00	4,0	116	2	7		54,96
25,00	7,0	121	2	9		60,27
31,50	9,0	124	2	9		82,43
40,00	12,5	150	3	11		150,85
50,00	16,0	153	3	13		180,23
63,00	20,0	185	4	15		258,76
80,00	25,0	196	4	17		426,56
100,00	22,0	190	4	20		1.149,84

						AV24
						HSS
D ₁ mm.	D _{min} mm.	L ₁ mm.	CM	Z		€
16,00	3,2	93	1	7		46,08
20,00	4,0	116	2	7		53,93
25,00	7,0	121	2	9		61,93
31,50	9,0	124	2	9		80,80
40,00	12,5	150	3	11		129,89
50,00	16,0	153	3	13		167,78
63,00	20,0	185	4	15		270,57
80,00	25,0	196	4	17		418,16
100,00	27,0	210	4	3		1.097,48

AVELLANADORES DE 1 CANAL

1Z

MANGO CILÍNDRICO

Ref. **AV27**

HSS



Ref. **AV29**

HSS

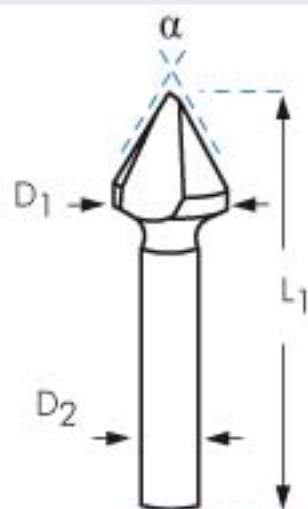

				AV27			AV29
	D ₁ mm.	D ₂ mm.	L ₁ mm.	€			€
AV270600	6,0	6,0	45	10,19	AV290600		18,35
AV270800	8,0	8,0	50	11,30	AV290800		19,23
AV271000	10,0	8,0	50	11,98	AV291000		20,12
AV271200	12,0	8,0	50	14,38	AV291200		22,61
AV271600	16,0	10,0	56	17,46	AV291600		27,53
AV272000	20,0	10,0	60	25,81	AV292000		35,38
AV272500	25,0	12,0	75	34,00	AV292500		55,71
AV273000	30,0	12,0	80	49,04	AV293000		72,75
AV274000	40,0	13,0	89	107,09	AV294000		126,47
AV275000	50,0	13,0	98	132,21	AV295000		188,94

1Z

MANGO CÓNICO

Ref. **AV34**

HSS



Ref. **AV28**

HSS

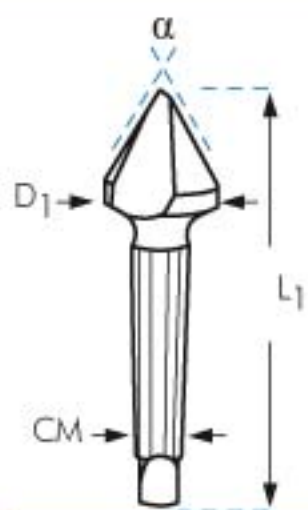

				AV34			AV28
	D ₁ mm.	CM	L ₁ mm.	€			€
AV341600	16,0	1	92	49,04	AV281600		46,91
AV342000	20,0	2	107	61,44	AV282000		51,39
AV342500	25,0	2	110	79,13	AV282500		76,19
AV343000	30,0	2	114	89,92	AV283000		100,41
AV344000	40,0	3	145	144,68	AV284000		132,20
AV345000	50,0	3	152	211,26	AV285000		200,76

AVELLANADORES PARA ASIENTOS DE TORNILLOS «ALLEN»

Avellanadores

Rosa

MANGO CILÍNDRICO

DIN 373

HSS

Ref. **AV2**

NOTA: La longitud de corte se entiende sin la guía.

* El ajuste grueso se utiliza para avellanar agujeros roscados.

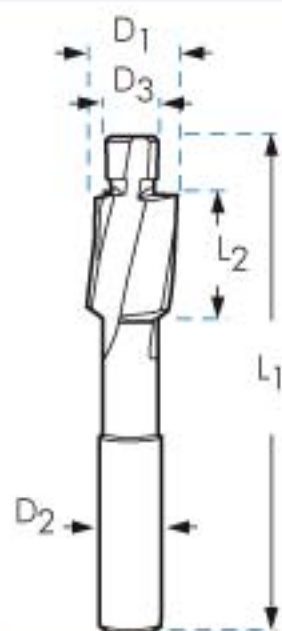

AV2					AV2M					AV2G									
AJUSTE					FINO					MEDIO					GRUESO				
	D ₁ mm.	D ₂ mm.	L ₁ mm.	L ₂ mm.		D ₃ mm.	€		D ₃ mm.	€		D ₃ mm.	€						
M3	6,0	5,0	71	14	AV2M3	3,2	16,44	AV2MM3	3,4	16,44	AV2GM3	2,5	16,44						
M4	8,0	5,0	71	14	AV2M4	4,3	16,44	AV2MM4	4,5	16,44	AV2GM4	3,3	16,44						
M5	10,0	8,0	80	18	AV2M5	5,3	16,44	AV2MM5	5,5	16,44	AV2GM5	4,2	16,44						
M6	11,0	8,0	80	18	AV2M6	6,4	18,53	AV2MM6	6,6	18,53	AV2GM6	5,0	18,53						
M7	20,0	12,7	90	20	AV2M7	7,4	33,25												
M8	15,0	12,5	100	22	AV2M8	8,4	23,20	AV2MM8	9,0	23,20	AV2GM8	6,8	23,20						
M9	22,0	16,0	100	22	AV2M9	9,4	33,25												
M10	18,0	12,5	100	22	AV2M10	10,5	25,22	AV2MM10	11,0	25,22	AV2GM10	8,5	25,22						
M11	22,0	18,8	100	22	AV2M11	11,5	35,36												
M12	20,0	12,5	100	22	AV2M12	13,0	29,85	AV2MM12	14,0	29,85	AV2GM12	10,2	29,85						
M14	24,0	16,0	100	22	AV2M14	15,0	38,32	AV2MM14	15,5	38,32	AV2GM14	12,0	38,32						
M16	26,0	16,0	100	22	AV2M16	17,0	42,82	AV2MM16	17,5	42,82	AV2GM16	14,0	42,82						

CABEZA CÓNICA CON GUÍA

DIN 1866

HSS

Ref. **AV3**

NOTA: La longitud de corte se entiende sin la guía.

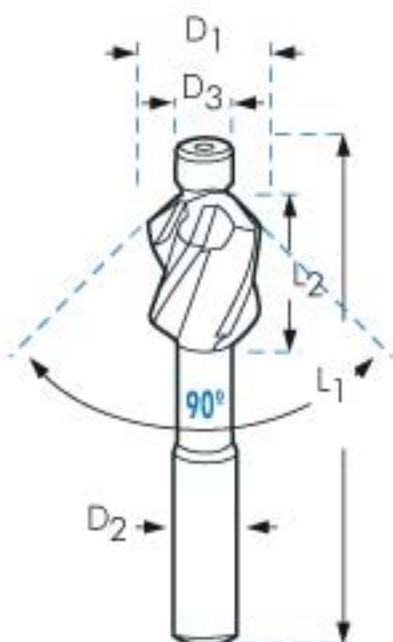

AV3					FINO					
AJUSTE					FINO					
	D ₁ mm.	D ₂ mm.	L ₁ mm.	L ₂ mm.		D ₃ mm.	€		D ₃ mm.	€
M3	6,3	6,0	71	14,0	AV3M3	3,20	24,09			
M4	8,3	8,0	71	14,0	AV3M4	4,30	24,09			
M5	10,4	10,0	80	18,0	AV3M5	5,30	24,09			
M6	12,4	10,0	80	18,0	AV3M6	6,40	27,37			
M8	16,5	12,0	100	22,0	AV3M8	8,40	33,49			
M10	20,5	12,0	100	22,0	AV3M10	10,50	36,25			
M12	24,5	13,0	110	25,0	AV3M12	13,00	44,17			
M14	28,0	13,0	110	25,0	AV3M14	15,00	60,89			
M16	32,5	13,0	120	30,0	AV3M16	17,00	66,49			
M18	36,5	13,0	120	30,0	AV3M18	19,00	95,37			
M20	40,5	13,0	120	30,0	AV3M20	21,00	113,09			

AVELLANADORES PARA ASIENTOS DE TORNILLOS «ALLEN»

MANGO CÓNICO

Ref. **AV5**

DIN
375

HSS

NOTA: La longitud de corte se entiende sin la guía.

* El ajuste grueso se utiliza para avellanar agujeros roscados.

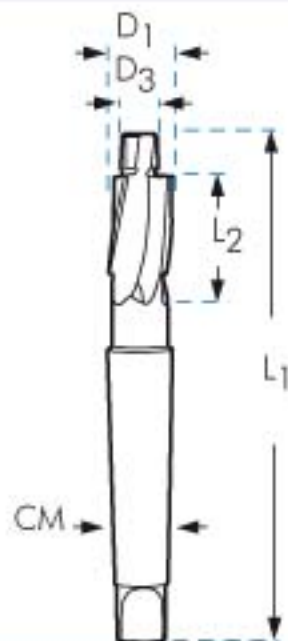

AV5					AV5M		AV5G						
FINO					MEDIO		GRUESO						
AJUSTE	D1 mm.	CM	L1 mm.	L2 mm.	D3 mm.	€	D3 mm.	€	D3 mm.	€			
M7	20,0	2	125	22	AV5M7	7,4	46,36						
M8	15,0	2	132	22	AV5M8	8,4	42,38	AV5MM8	9,0	42,38	AV5GM8	6,8	42,38
M9	22,0	2	140	22	AV5M9	9,4	55,36						
M10	18,0	2	140	25	AV5M10	10,5	46,09	AV5MM10	11,0	46,09	AV5GM10	8,5	46,09
M11	22,0	2	140	25	AV5M11	11,5	58,36						
M12	20,0	2	140	25	AV5M12	13,0	48,62	AV5MM12	14,0	48,62	AV5GM12	10,2	48,62
M13	22,0	2	150	25	AV5M13	14,0	63,25						
M14	24,0	2	150	30	AV5M14	15,0	56,85	AV5MM14	15,5	56,85	AV5GM14	12,0	56,85
M15	22,0	2	160	30	AV5M15	16,0	72,21						
M16	26,0	3	180	35	AV5M16	17,0	63,81	AV5MM16	17,5	63,81	AV5GM16	14,0	63,81
M18	30,0	3	180	35	AV5M18	19,0	80,37	AV5MM18	20,0	80,37	AV5GM18	15,5	80,37
M20	33,0	3	190	40	AV5M20	21,0	88,65	AV5MM20	22,0	88,65	AV5GM20	17,5	88,65
M22	36,0	3	190	40	AV5M22	23,0	101,64	AV5MM22	24,0	101,64	AV5GM22	19,5	101,64
M24	40,0	3	190	40	AV5M24	25,0	115,83	AV5MM24	26,0	115,83	AV5GM24	21,0	115,83
M27	40,0	3	190	40	AV5M27	28,0	145,36						
M30	40,0	3	190	40	AV5M30	31,5	192,24						

APLICACIONES DE LOS TIPOS DE AJUSTES: FINO, MEDIO Y GRUESO

T₁ : Tornillos Cabeza Cilíndrica DIN 84 y DIN 7984

Tornillos Rosca Cortante DIN 7513 B

Tornillos Autorroscantes DIN 7500 B

T₂ : Tornillos Cabeza Cilíndrica DIN 6912

T₃ : Tornillos Cabeza Cilíndrica DIN 912

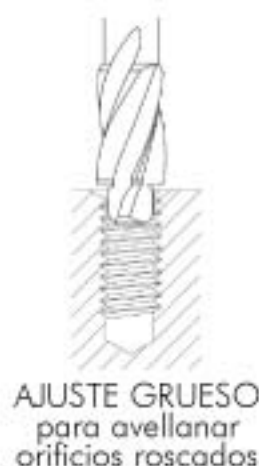
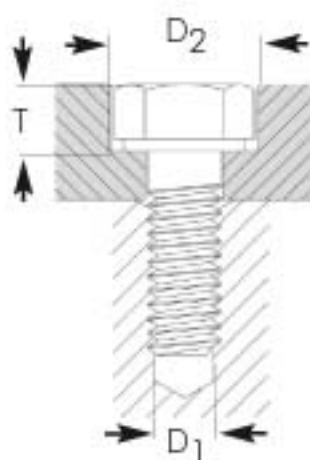

ROSCAS MÉTRICAS	FINO D1 mm.	MEDIO D1 mm.	GRUESO D1 mm.	D2 mm.	T1 mm.	T2 mm.	T3 mm.
M 3	3,2	3,4	2,5	6,0	2,4	--	3,4
M 4	4,3	4,5	3,3	8,0	3,2	3,4	4,6
M 5	5,3	5,5	4,2	10,0	4,0	4,2	5,7
M 6	6,4	6,6	5,0	11,0	4,7	4,8	6,8
M 8	8,4	9,0	6,8	15,0	6,0	6,0	6,0
M 10	10,5	11,0	8,5	18,0	7,0	7,5	11,0
M 12	13,0	13,5	10,2	20,0	8,0	8,5	13,0
M 14	15,0	15,5	12,0	24,0	9,0	9,5	15,0
M 16	17,0	17,5	14,0	26,0	10,5	11,5	17,5
M 18	19,0	20,0	15,5	30,0	11,5	12,5	19,5
M 20	21,0	22,0	17,5	33,0	12,5	13,5	21,5
M 22	23,0	24,0	19,5	36,0	13,5	14,5	23,5

AVELLANADORES CON ELEMENTOS INTERCAMBIABLES PARA ASIENTOS DE TORNILLOS CON CABEZA "ALLEN" Y CÓNICA

Avellanadores

Rosa



EL SISTEMA BLUEMASTER

El sistema BLUEMASTER es único para operaciones de cajeado y avellanado, ayudándole a incrementar su productividad y disminuir sus costes.

Nuestros portaherramientas, fresas, brocas y guías pueden combinarse para adaptarlos a todo tipo de máquinas y aplicaciones.

Usted puede componer fácilmente más de 1.500.000 de herramientas especiales con solo 1.300 piezas.

El sistema consta de 3 grupos de dimensiones: **SERIE A, SERIE B y SERIE C.**

Todas las combinaciones tienen que hacerse con elementos que pertenezcan al mismo grupo. Herramientas de distintos grupos no son combinables entre sí.

En las siguientes páginas encontrará tanto los rangos de medidas disponibles en cada grupo, así como recomendaciones para la correcta elección tanto de la herramienta como de los datos de corte.

Importante!

- * Usando corte de metal duro colocar el tornillo de ajuste axial en contacto con la guía o broca insertada.
- * Dejar un espacio entre el filo y la guía o broca para prevenir roturas por impacto accidental.
- * El tornillo axial también se usa para prolongar la vida de las brocas tras reafilarlas.

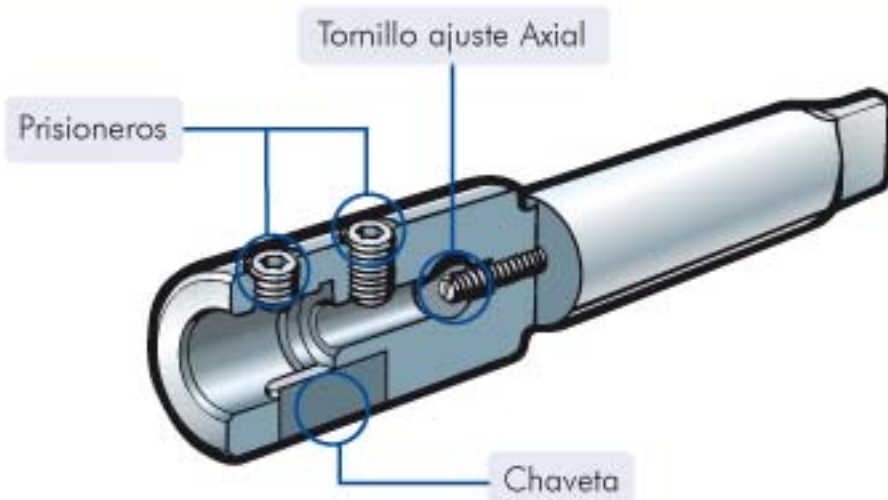

DIMENSIONES DE GUÍA, PORTA Y BROCA

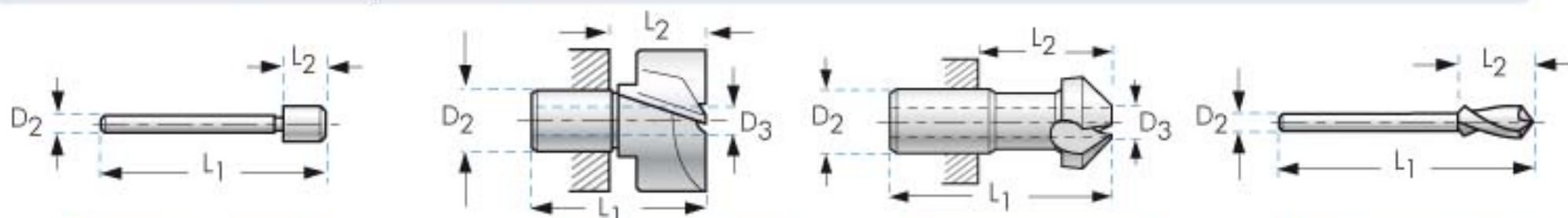

GUÍA			PORTAS				AVELLANADOR				BROCA						
D ₂	L ₁	L ₂	D ₂	D ₃	L ₁	L ₂	D ₂	D ₃	L ₁	L ₂	D ₂	L ₁	L ₂				
mm.	mm.	mm.	mm.	mm.	mm.	mm.	mm.	mm.	mm.	mm.	mm.	mm.	mm.				
AGP	4	64	9	APAV-MD-PQ	10	4	40	22	AVC	10	4	40	22	ABP	4	70	15
BGP	6	80	14	BPAV-MD-PQ	14	6	48	28	BVC	14	6	48	28	BBP	6	95	25
CGP	10	110	20	CPAV-MD-PQ	22	10	61	33	CVC	22	10	61	33	CBP	10	125	30

AVELLANADORES CON ELEMENTOS INTERCAMBIABLES PARA ASIENTOS DE TORNILLOS CON CABEZA "ALLEN" Y CÓNICA

SERIE A



	GUÍA	PORTA	PORTA	PLAQUITA INTERCAMBIABLE	AVELLANADOR	BROCA
	AGP	APAV	APAVMD	APAVPQ	AVC	ABP
MÉTRICAS AJUSTE		HSS	MD	Plaquita no incluida PMD	90° HSS	HSS
	€	€	€	€	€	€
						ABP0430 38,01
						ABP0450 38,01
						ABP0500 38,01
						ABP0530 38,01
						ABP0550 38,01
					AVC0800 87,23	ABP0600 44,67
						ABP0640 44,67
					AVC1000 87,23	ABP0650 44,67
M6	F AGP0640 26,15					
	M AGP0660 26,15	APAV1100 66,11	APAVMD1100 187,95		AVC1200 88,53	ABP0660 44,67
	V AGP0500 26,15					
		APAV1150 73,10				ABP0700 44,67
		APAV1200 66,93	APAVMD1200 187,95		AVC1150 85,61	
		APAV1250 74,24			AVC1240 89,56	
		APAV1300 72,94	APAVMD1300 187,95			
		APAV1350 83,98			AVC1350 89,56	
		APAV1400 72,94	APAVMD1400 189,74		AVC1400 96,00	
		APAV1450 84,15				
M8	F AGP0840 26,48					
	M AGP0900 26,48	APAV1500 73,75	APAVMD1500 191,85		AVC1500 191,85	
	V AGP0680 26,15					
	AGP0700 26,15	APAV1600 77,97	APAVMD1600 196,23		AVC1600 97,30	
	AGP0750 26,15	APAV1700 79,44	APAVMD1700 200,46		AVC1650 94,71	
	AGP0800 26,48	APAV1800 81,55	APAVMD1800 204,68	APAVPQ1800 427,55		
	AGP0850 26,48	APAV1900 86,75	APAVMD1900 213,94			
	AGP0900 26,48	APAV2000 89,83	APAVMD2000 218,49	APAVPQ2000 479,21		
	AGP0950 26,48	APAV2100 97,95	APAVMD2100 228,88			
	AGP1000 26,48					
	AGP1050 26,48					
	AGP1100 26,48					
	AGP1150 26,48					

ADAPTADORES



	D ₁	D ₂	L ₁	L ₂	CM	APH
	mm.	mm.	mm.	mm.	Ømm.	€
APHCM1	18	10	110	48	CM1	156,76
APHCM2	18	10	132	57	CM2	153,83
APH-10	18	10	92	42	Ø10	146,52

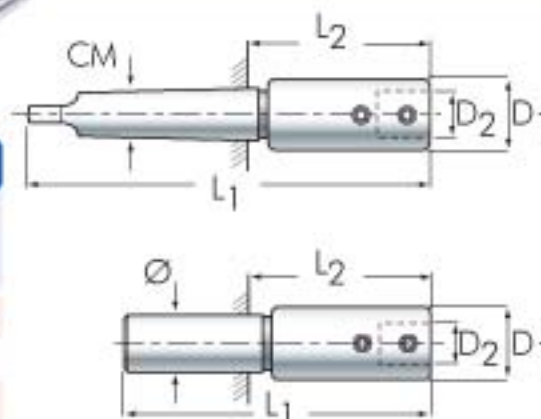

PLAQUITAS DE REPUESTO

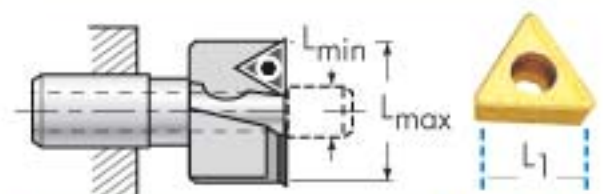

	L ₁	L _{min}	L _{max}	PPQ
	mm.	mm.	mm.	€
PPQ7	7	18	20	16,24

AVELLANADORES CON ELEMENTOS INTERCAMBIABLES PARA ASIENTOS DE TORNILLOS CON CABEZA "ALLEN" Y CÓNICA

SERIE B



	BGP	BPAV	BPAVMD	BPAVPQ	BVC	BBP
MÉTRICAS AJUSTE	€	HSS €	MD €	Plaquita no incluida PMD €	90° HSS €	HSS €
		BPAV1300 74,07 BPAV1350 83,66 BPAV1400 74,07 BPAV1450 83,66	BPAVMD1300 200,46 BPAVMD1400 200,46			BBP0800 53,12
MB	F BGP0840 24,69 M BGP0900 24,69 B BGP0680 24,69	BPAV1500 74,07	BPAVMD1500 200,46		BVC1500 91,94	BBP0900 53,12
	BGP0800 24,69 BGP1000 24,69 BGP1150 26,15 BGP1250 27,13 BGP1350 29,89 BGP1450 30,21	BPAV1550 84,80 BPAV1600 78,14 BPAV1650 90,64 BPAV1700 81,38 BPAV1750 91,29 BPAV1900 93,89	BPAVMD1600 207,93 BPAVMD1700 207,93			BBP0840 53,12 BBP0850 53,12 BBP0950 53,12 BBP1000 60,59 BBP1050 60,59
M10	F BGP1050 26,15 M BGP1100 26,15 B BGP0850 24,69	BPAV1800 84,47	BPAVMD1800 209,72		BVC2000 103,96	BBP1100 60,59
M12	F BGP1300 29,89 M BGP1400 30,21 B BGP1020 26,15	BPAV2000 93,89	BPAVMD2000 216,21	BPAVPQ2000 427,91	BVC2500 108,19	
M14	F BGP1500 30,21 M BGP1550 30,21 B BGP1200 26,15	BPAV2400 110,95	BPAVMD2400 229,70	BPAVPQ2400 428,46	BVC2800 125,89	
M16	F BGP1700 30,21 M BGP1750 30,21 B BGP1400 30,21	BPAV2600 118,58	BPAVMD2600 231,00	BPAVPQ2600 491,26	BVC3000 128,66	
M18	F BGP1900 30,86 M BGP2000 38,50 B BGP1550 30,21	BPAV3000 160,17	BPAVMD3000 251,95	BPAVPQ3000 491,26		
M20	F M B BGP1750 30,21	BPAV3400 189,41	BPAVMD3400 290,59	BPAVPQ3400 567,02		

ADAPTADORES



	D ₁	D ₂	L ₁	L ₂	CM	BPH
	mm.	mm.	mm.	mm.	Ømm.	€
BPHCM1	24	14	123	62	CM1	173,82
BPHCM2	24	14	137	62	CM2	158,71
BPHCM3	24	14	160	66	CM3	173,82
BPH-12	24	14	120	55	Ø12	156,92

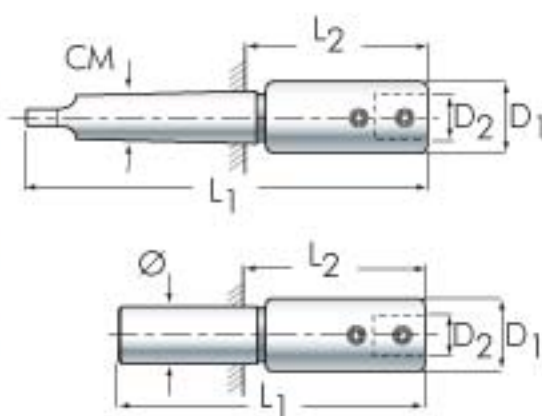

PLAQUITAS DE REPUESTO

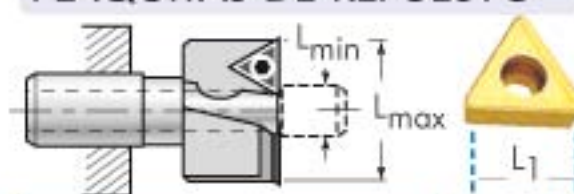

	L ₁	L _{min}	L _{max}	PPQ
	mm.	mm.	mm.	€
PPQ07	7	20	25	16,24
PPQ10	10	26	33	14,62
PPQ12	12	34	36	14,62

AVELLANADORES CON ELEMENTOS INTERCAMBIABLES PARA ASIENTOS DE TORNILLOS CON CABEZA "ALLEN" Y CÓNICA

SERIE
C



MÉTRICAS AJUSTE	CGP		CPAV		CPAVMD		CPAVPQ		CVC		CBP	
		€		€		€	Plaquita no incluida	€	90° HSS	€		€
	CGP1200	28,10	CPAV2300	134,50	CPAVMD2300	250,65						
	CGP1250	28,10	CPAV2400	136,29	CPAVMD2400	248,05						
	CGP1300	28,10	CPAV2500	147,34	CPAVMD2500	248,54						
	CGP1350	28,10	CPAV2600	150,26	CPAVMD2600	255,36						
	CGP1400	32,98	CPAV2700	152,37								
	CGP1450	32,98	CPAV2800	155,30	CPAVMD2800	257,80					CBP1700	132,72
	CGP1500	32,98	CPAV2900	159,03							CBP1800	149,61
	CGP1600	32,98	CPAV3100	172,84							CBP1900	156,92
	CGP1650	32,98	CPAV3200	178,53	CPAVMD3200	284,28					CBP2100	170,08
	CGP1700	32,98	CPAV3300	180,15							CBP2300	204,68
M18	F CGP1900	32,98										
	M CGP2000	32,98	CPAV3000	161,14	CPAVMD3000	281,52			CVC35	187,62	CBP2000	170,08
	B CGP1550	32,98										
M20	F CGP2100	36,71										
	M CGP2200	36,71	CPAV3400	181,94	CPAVMD3400	302,15	CPAVPQ3400	586,37	CVC37	198,51	CBP2200	189,74
	B CGP1750	32,98										
	CGP1850	32,98	CPAV3500	190,55								
M22	F CGP2300	36,71										
	M CGP2400	36,71	CPAV3600	192,82	CPAVMD3600	310,43	CPAVPQ3600	586,37	CVC37	198,51	CBP2400	209,07
	B CGP1950	32,98										
M24	F CGP2500	36,71										
	M CGP2600	45,16	CPAV4000	223,85	CPAVMD4000	343,89	CPAVPQ4000	599,88	CVC40	211,02		
	B CGP2100	36,71										
	CGP2200	36,71	CPAV4500	276,16			CPAVPQ4500	610,83				
	CGP2050	36,71	CPAV5000	401,08			CPAVPQ5000	714,71				
			CPAV5500	422,52			CPAVPQ5500	844,14				
			CPAV6000	445,26			CPAVPQ6000	844,14				
			CPAV6500	500,82			CPAVPQ6500	965,35				

ADAPTADORES

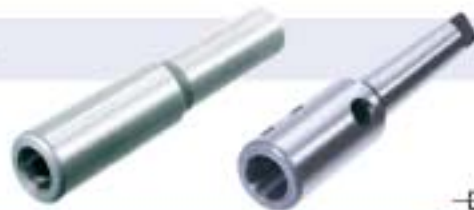

	D ₁	D ₂	L ₁	L ₂	CM	CPH
	mm.	mm.	mm.	mm.	Ømm.	€
CPHCM2	36	22	160	85	CM2	228,88
CPHCM3	36	22	180	87	CM3	216,21
CPHCM4	36	22	206	89	CM4	242,37
CPHCM5	36	22	240	91	CM5	533,31
CPH-12	36	22	140	71	Ø12	156,92

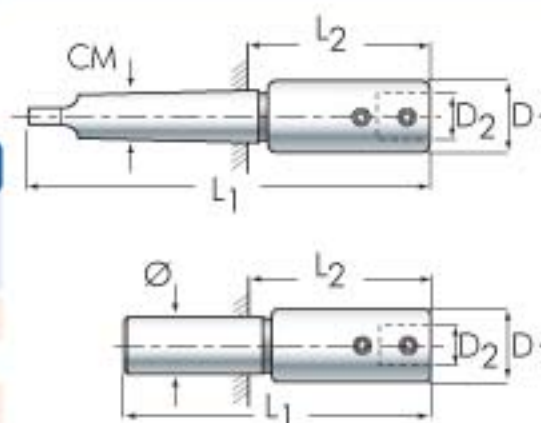

PLAQUITAS DE REPUESTO

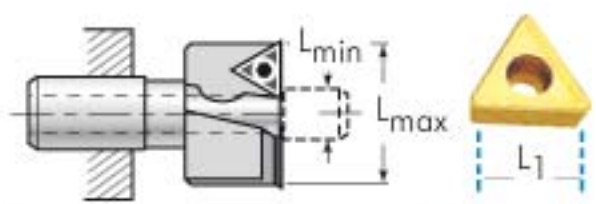

	L ₁	L _{min}	L _{max}	PPQ
	mm.	mm.	mm.	€
PPQ12	12	34	45	14,62
PPQ17	17	<46		22,25

Avellanadores
Rosa

ESTUCHES METÁLICOS DE AVELLANADORES

ESTUCHES DE BROCAS AVELLANADORAS PARA TUBO Y CHAPA HSS y HSS-Co

HSS



(Brocas Ref. AV30)

REFERENCIA	AV30BM012
Nº BROCAS	3
CALIDAD	HSS
CONTENIDO	AV30BM0 - AV30BM1 - AV30BM2
P.V.P. €	85,54
€	162,34

HSS-Co



(Brocas Ref. AVC30)

REFERENCIA	AVC30BM012
Nº BROCAS	3
CALIDAD	HSS-Co
CONTENIDO	AV30CBM0 - AV30CBM1 - AV30CBM2
P.V.P. €	123,19
€	181,97

ESTUCHES DE BROCAS ESCALONADAS CON CANALES RECTOS HSS y HSS-Co

HSS

HSS-Co

(Brocas Ref. AV40)

REFERENCIA	AV40BM234	AV40BM22122
Nº BROCAS	3	3
CONTENIDO	AV40BM2 - AV40BM3 - AV40BM4	AV40BM2 - AV40BM21 - AV40BM22
P.V.P. €	173,59	202,55
€	251,76	251,76
P.V.P. €	208,11	
€	301,29	



Ref. **AV40BM234**

ESTUCHE DE BROCAS ESCALONADAS HELICOIDALES HSS

HSS

(Brocas Ref. AV42)

REFERENCIA	AV42BM234
Nº BROCAS	3
CALIDAD	HSS
CONTENIDO	AV42BM2 - AV42BM3 - AV42BM4
P.V.P. €	213,67
€	280,78



Ref. **AV42BM234**

ESTUCHES METÁLICOS DE AVELLANADORES

Avellanadores

Rosa



(Avellanadores Ref. AV6)

REFERENCIA	AV6CM1	AV6CM2	AV6CM3
Nº BROCAS	6	6	7
CONTENIDO	Ø 6 - 8 - 10 - 11,5 - 15 - 19 mm.	Ø 6,3 - 8,3 - 10,4 - 12,4 - 16,5 - 20,5	Ø 6,3 - 8,3 - 10,4 - 12,4 - 16,5 - 20,5 - 25
P.V.P. €	116,00	110,12	162,88



(Avellanadores Ref. AV7)

REFERENCIA	AV7CM1	AV7CM2	AV7CM3
Nº BROCAS	6	6	7
CONTENIDO	Ø 6 - 8 - 10 - 11,5 - 15 - 19 mm.	Ø 6,3 - 8,3 - 10,4 - 12,4 - 16,5 - 20,5	Ø 6,3 - 8,3 - 10,4 - 12,4 - 16,5 - 20,5 - 25
P.V.P. €	135,22	138,73	203,03



(Avellanadores Ref. AV16)

REFERENCIA	AV16CM1	AV16CM2	AV16CM3
Nº BROCAS	6	6	7
CONTENIDO	Ø 6 - 8 - 10 - 11,5 - 15 - 19 mm.	Ø 6,3 - 8,3 - 10,4 - 12,4 - 16,5 - 20,5	Ø 6,3 - 8,3 - 10,4 - 12,4 - 16,5 - 20,5 - 25
P.V.P. €	219,96	218,01	298,49



(Avellanadores Ref. AV8)

REFERENCIA	AV8CM2	AV8CM3
Nº BROCAS	6	7
CONTENIDO	Ø 6,3 - 8,3 - 10,4 - 12,4 - 16,5 - 20,5	Ø 6,3 - 8,3 - 10,4 - 12,4 - 16,5 - 20,5 - 25
P.V.P. €	156,36	202,15



(Avellanadores Ref. AV9)

REFERENCIA	AV9CM1	AV9CM5
Nº BROCAS	6	7
CONTENIDO	Ø 6,3 - 8,3 - 10,4 - 12,4 - 16,5 - 20,5	Ø 6,3 - 8,3 - 10,4 - 12,4 - 16,5 - 20,5 - 25
P.V.P. €	159,91	206,95



(Avellanadores Ref. AV10)

REFERENCIA	AV10CM1	AV10CM6
Nº BROCAS	6	7
CONTENIDO	Ø 6,3 - 8,3 - 10,4 - 12,4 - 16,5 - 20,5	Ø 6,3 - 8,3 - 10,4 - 12,4 - 16,5 - 20,5 - 25
P.V.P. €	179,91	222,71



Ref. **AV6CM2**

* Otros estuches bajo demanda AV19, etc...

ESTUCHES METÁLICOS DE AVELLANADORES

ESTUCHES DE AVELLANADORES PARA DESBARBAR CON AGUJERO DE 90° HSS y HSS-Co



(Avellanadores Ref. AV1)

REFERENCIA	AV1S1	AV1S2
Nº AVELLANADORES	4	5
CONTENIDO	Ø 10 - 14 - 20 - 27 mm.	Ø 10 - 14 - 20 - 27 - 30 mm.
P.V.P. € HSS	139,81	226,28
€ HSS TiN	204,97	323,31



(Avellanadores Ref. AV2)

REFERENCIA	AV2S1	AV2S2
Nº AVELLANADORES	4	5
CONTENIDO	Ø 10 - 14 - 20 - 27 mm.	Ø 10 - 14 - 20 - 27 - 30 mm.
P.V.P. € HSS-Co	172,19	284,81
€ HSS-Co TiN	249,89	398,74



Ref. **AV1S1**

ESTUCHES DE AVELLANADORES PARA ASIENTOS DE TORNILLOS "ALLEN" AJUSTE FINO, MEDIO Y GRUESO



(Avellanadores Ref. AV2M3)

REFERENCIA	AV2M3-10	AV2M3-12
Nº BROCAS	6	7
CONTENIDO	M3 - M4 - M5 - M6 - M8 - M10	M3 - M4 - M5 - M6 - M8 - M10 - M12
P.V.P. €	127,94	156,49



REFERENCIA	AV2M3-10M	AV2M3-12M
Nº BROCAS	6	7
CONTENIDO	M3 - M4 - M5 - M6 - M8 - M10	M3 - M4 - M5 - M6 - M8 - M10 - M12
P.V.P. €	127,94	156,49



REFERENCIA	AV2M3-10G	AV2M3-12G
Nº BROCAS	6	7
CONTENIDO	M3 - M4 - M5 - M6 - M8 - M10	M3 - M4 - M5 - M6 - M8 - M10 - M12
P.V.P. €	127,94	156,49



Ref. **AV2M3-10**

REBARBADORES DE PRECISIÓN

LOS REBARBADORES BLUEMASTER

Los rebarbadores BLUEMASTER se emplean para eliminar las virutas acumuladas en bordes y aristas de piezas fabricadas en Metal, plástico o Madera.

El mango puede ser utilizado con todos los grupos de cuchillas, intercambiando oportunamente el portacuchillas para cada uno de ellos.

El sistema se completa ensamblando los tres componentes señalados:

CUCHILLA + PORTACUCHILLAS + MANGO UNIVERSAL

PORTACUCHILLAS
Extensible hasta 100 mm.



MANGO REBARBADOR UNIVERSAL

Usos generales.
Válido para portacuchillas:
Ref.RBB / RBC / RBD / RBE / RBF



RBB1

Blister 1Ud.: **10,24 €**

REBARBADORES DE PRECISIÓN

GRUPO B

PORTACUCHILLAS GRUPO B



Para cuchillas rebarbadoras Grupo B

RBB

Blister 1Ud.: **7,80 €**

CUCHILLAS GRUPO B



Cuchilla rebarbadora Serie Corta: Acero, Aluminio, Plástico

RB10

Blister 10Uds: **1,36 €**



Cuchilla punzonadora de Metal Duro

RB50

Blister 1Ud.: **24,44 €**



Cuchilla rebarbadora Bidireccional Serie Corta :Latón, fundición

RB20

Blister 10Uds: **1,36 €**



Cuchilla rebarbadora para parte posterior de un taladro de hasta 20 mm. de profundidad

RB60

Blister 10Uds.: **2,84 €**



Cuchilla rebarbadora doble arista agujeros de 4mm. de profundidad

RB30

Blister 10Uds: **1,36 €**



Cuchilla rebarbadora de aristas exteriores

RB70MD

Blister 1Ud.: **29,18 €**

GRUPO C

PORTACUCHILLAS GRUPO C



Para cuchillas rebarbadoras Grupo C

RBC

Blister 1Ud.: **7,80 €**

CUCHILLAS GRUPO C



Cuchilla rasqueta ancho 4 x 20 mm.

RC40

Blister 1Ud.: **15,89 €**



Cuchilla rasqueta ancho 8 x 30 mm.

RC42

Blister 1Ud.: **19,76 €**

GRUPO D

PORTACUCHILLAS GRUPO D



Para cuchillas rebarbadoras Grupo D

RBD

Blister 1Ud.: **7,80 €**

CUCHILLAS GRUPO D



Cuchilla rebarbadora de Metal Duro en "V" Hembra cantos hasta 3 mm.

RD80MD

Blister 1Ud.: **41,53 €**



Cuchilla rebarbadora de Metal Duro en "V" Hembra cantos hasta 8 mm.

RD82MD

Blister 1Ud.: **65,11 €**

REBARBADORES DE PRECISIÓN



GRUPO E

PORTACUCHILLAS GRUPO E



Para cuchillas rebarbadoras Grupo E

RBE

Blister 1Ud.: **7,80 €**

CUCHILLAS GRUPO E



Cuchilla rebarbadora para interiores y exteriores Serie Larga: Acero, Aluminio, Plástico

RE10

Blister 10Uds: **1,69 €**



Cuchilla rebarbadora para cantos rectos: Chaveteros,...

RE35

Blister 10Uds.: **1,80 €**



Cuchilla rebarbadora Bidireccional Serie Larga :Latón, fundición

RE20

Blister 10Uds: **1,69 €**



Cuchilla rebarbadora para la parte posterior de un taladro de hasta 20 mm. de profundidad

RE30

Blister 10Uds: **1,69 €**

RE60

Blister 5Uds.: **2,36 €**

Cuchilla rebarbadora cerrada doble arista para agujeros de 4 mm. de profundidad

GRUPO F

PORTACUCHILLAS GRUPO F



Para cuchillas rebarbadoras Grupo F

RBF

Blister 1Ud.: **7,80 €**

CUCHILLAS GRUPO F



Cuchilla avellanadora HSS 12 mm.

RF12

Blister 1Ud.: **17,53 €**



Cuchilla avellanadora HSS 30 mm.

RF30

Blister 1Ud.: **58,58 €**



Cuchilla avellanadora HSS 20 mm.

RF20

Blister 1Ud.: **33,89 €**

CONJUNTOS DE REBARBADORES DE PRECISIÓN



CONJUNTO B

JRB1

Contenido **B**:

Ref. RB10



Ref. RBB1



Ref. RB20



Ref. RBB



Blister: 22,21 €

CONJUNTO C

JRB2

Contenido **C**:

Ref. RC42



Ref. RBB1



Ref. RBC



Blister: 40,45 €

CONJUNTO D

JRB3

Contenido **D**:

Ref. RD80MD



Ref. RBB1



Ref. RBD



Blister: 63,75 €

CONJUNTO E

JRB4

Contenido **E**:

Ref. RE10



Ref. RBB1



Ref. RE20



Ref. RE30

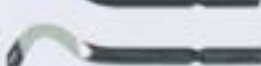

Ref. RBE

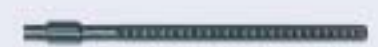

Blister: 24,73 €

CONJUNTO F

JRB5

Contenido **F**:

Ref. RF20



Ref. RBB1



Ref. RBF



Blister: 55,57 €

CONJUNTO A1

JRB6

Contenido **A1**:

Ref. RE10



Ref. RBB2*



Blister: 12,77 €

CONJUNTO A2

JRB7

Contenido **A2**:

Ref. RE10



Ref. RE20



Ref. RE30

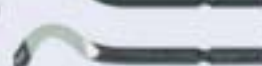

Ref. RBB2*



Blister: 16,50 €

* Ref. RBB2 Mango válido únicamente para cuchillas grupo E sin necesidad del portacuchillas correspondiente