

FORMONES Y GUBIAS FRESAS DE MADERA DE ALTO RENDIMIENTO

TARGET[®]
by I.P.T.



GUBIAS

GUBIAS CON MANGO DE MADERA REFORZADO, DIN 5142 REF. CGS

Referencia	Medida	€
CGS06	6	7,62
CGS08	8	7,62
CGS10	10	7,69
CGS12	12	9,61
CGS16	16	9,61
CGS20	20	12,17
CGS26	26	16,02



FUNDA MAGNÉTICA PARA MEJOR SUJECIÓN

- Hoja fabricada según norma DIN 5142 en alto Cromo Vanadio, endurecido y templado hasta conseguir una dureza de HRC 59-62. Acabado rectificado. Mango de madera. Gama de 6 a 26 mm

FORMONES

FORMONES CON MANGO DE MADERA REFORZADO REF. CGS



Referencia	Medida	€
CMS06	6	5,45
CMS08	8	5,45
CMS10	10	5,81
CMS12	12	5,81
CMS14	14	6,32
CMS16	16	6,32
CMS18	18	6,77
CMS20	20	6,77
CMS22	22	7,19
CMS24	24	7,19
CMS25	25	7,69
CMS26	26	7,69
CMS28	28	7,69
CMS30	30	8,88
CMS32	32	8,88
CMS35	35	9,61



FUNDA MAGNÉTICA PARA MEJOR SUJECIÓN

REF. F1

- CONTENIDO EXPOSITOR REF. F1 (60 FORMONES) **P.V.P. 432,28 €**

Ø	8	10	12	14	16	18	20	22	24	25	26	28	30	32	35
CANTIDAD	4	4	4	4	4	4	4	4	4	4	4	4	4	4	4

- Hoja fabricada según norma DIN 5139 en alto Cromo Vanadio, endurecido y templado hasta conseguir una dureza de HRC 59-62. Acabado rectificado. Mango de madera. Gama de 6 a 35 mm

FORMONES

FORMONES CON MANGO BIMATERIAL, REF. CBS



REF. F2



FUNDA MAGNÉTICA PARA MEJOR SUJECIÓN

Referencia	Medida	€
CBS06	6	6,32
CBS08	8	6,76
CBS10	10	6,76
CBS12	12	6,92
CBS14	14	7,03
CBS16	16	7,03
CBS18	18	7,14
CBS20	20	7,30
CBS22	22	7,30
CBS24	24	7,41
CBS25	25	7,41
CBS26	26	7,41
CBS28	28	7,69
CBS30	30	8,24
CBS32	32	8,40
CBS35	35	8,79
CBS38	38	8,79

- Hoja fabricada en alto Cromo Vanadio, endurecido y templado hasta conseguir una dureza de HRC 59-62. Acabado rectificado.
- Mango ergonómico bimaterial con refuerzo metálico integrado
- Gama de 6 a 38 mm

• CONTENIDO EXPOSITOR REF. F2 (60 FORMONES) **P.V.P. 454,48 €**

Ø	10	12	14	16	18	20	22	24	25	26	28	30	32	35	38
CANTIDAD	4	4	4	4	4	4	4	4	4	4	4	4	4	4	4



PIEDRA DE AFILADO, REF. CP8

- Piedra de carburo de silicio en combinación con una superficie fina y media de afilado.
Medida : 200X51X25 milímetros

P.V.P. 3,84 €

MAZO DE MADERA, REF. CMM1

- Sólido mazo de madera con caras en ángulo.
Cara de 50X55 milímetros



P.V.P. 9,89 €

JUEGO DE 6 FORMONES, REF. CB6120

- Hoja de Cromo Vanadio (Cr-V steel).
- Rugosidad anti-deslizamiento para apoyo de pulgar.
- Caja de madera.
- Mango bimaterial con refuerzo metálico.
- Contiene formones para madera de: **6,12,19,25,32 y 38 milímetros**

P.V.P. 44,39 €



JUEGO DE 5 FORMONES, REF. CB52

- Hoja de Cromo Vanadio (Cr-V steel).
- Maletin de plastico.
- Mango bimaterial.
- Contiene formones para madera de: **6,12,19,25 y 32 milímetros**

P.V.P. 34,32€



JUEGO DE 5 PIEZAS PARA MADERA, REF. CB51

- Hoja de Cromo Vanadio (Cr-V steel).
- Maletin de plástico.
- Mango bimaterial.
- Contiene formones para madera de: **12,19 y 25 milímetros**, mini cepillo y mazo de madera.

P.V.P. 32,95€



JUEGO DE 4 PIEZAS PARA MADERA, REF. CB41

- Hoja de Cromo Vanadio (Cr-V steel).
- Maletin de plástico.
- Mango bimaterial.
- Contiene formones para madera de: **6,19 y 25 milímetros** y una piedra de afilado.

P.V.P. 23,07€



JUEGO DE 3 PIEZAS PARA MADERA, REF. CB31

- Hoja de Cromo Vanadio (Cr-V steel).
- Estuche de plástico con colgador.
- Mango bimaterial.
- Contiene formones para madera de: **12,19 y 25 milímetros**.

P.V.P. 18,12€



SERIE PROFESIONAL

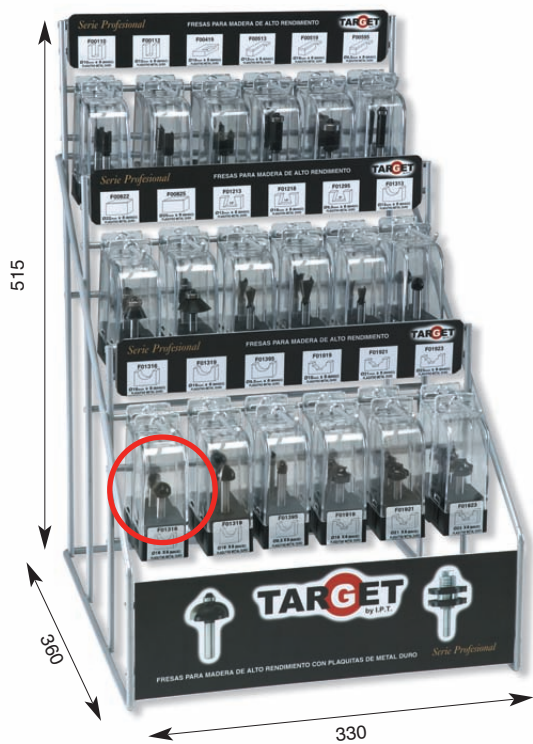

Composición Expositor nº1

Referencia	Descripción	Cant.
F00110	Fresas para ranurar dos labios	2
F00112	Fresas para ranurar dos labios	2
F00419	Fresas para ranurar bisagras	2
F00513	Fresas rectas para refundir con rodamiento	2
F00519	Fresas rectas para refundir con rodamiento	2
F00595	Fresas rectas para refundir con rodamiento	2
F00822	Fresas dos labios para biselar con rodamiento	2
F00825	Fresas dos labios para biselar con rodamiento	2
F01213	Fresas para ensamblar (cola de milano) dos labios	2
F01218	Fresas para ensamblar (cola de milano) dos labios	2
F01295	Fresas para ensamblar (cola de milano) dos labios	2
F01313	Fresas de radio convexo	2
F01316	Fresas de radio convexo	2
F01319	Fresas de radio convexo	2
F01395	Fresas de radio convexo	2
F01919	Fresas radio concavo para redondear cantos	2
F01921	Fresas radio concavo para redondear cantos	2
F01923	Fresas radio concavo para redondear cantos	2
	DOTACION SIN CARGO	
E1	Expositor nº1	1
GE1	Ganchos para expositor	18

P.V.P EXPOSITOR nº1

P.V.P. 362,88 €

Composición Expositor nº2

Referencia	Descripción	Cant.
F0168	Fresas para taladrar y refundir	2
F02025	Fresas radio concavo para redondear cantos con rod.	2
F02028	Fresas radio concavo para redondear cantos con rod.	2
F02032	Fresas radio concavo para redondear cantos con rod.	2
F02229	Fresas semicirculares	2
F02622	Fresas de radio convexo con rodamiento	2
F02629	Fresas de radio convexo con rodamiento	2
F02630	Fresas de radio convexo con rodamiento	2
F02635	Fresas de radio convexo con rodamiento	2
F02725	Fresas para perfilar con rodamiento	2
F02735	Fresas para perfilar con rodamiento	2
F03332	Fresas de radio convexo con rodamiento	2
F04725	Fresas para cajones	2
F04832	Fresas multiperfiles con rodamiento	2
F00110	Fresas para ranurar dos labios	2
F00112	Fresas para ranurar dos labios	2
F00513	Fresas rectas para refundir con rodamiento	2
F00519	Fresas rectas para refundir con rodamiento	2
	DOTACION SIN CARGO	
E1	Expositor nº1	1
GE1	Ganchos para expositor	18

P.V.P EXPOSITOR nº2

P.V.P. 642,12€

PRESENTACIÓN DE TODAS LAS FRESAS INCLUIDAS EN ESTE CATÁLOGO

**FRESAS PARA RANURAR DOS LABIOS
REF. F066**

METAL DURO INTEGRAL (MANGO DE ACERO)

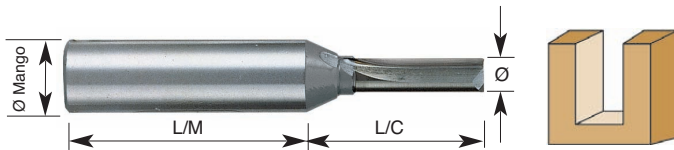

Referencia	Ø	Ø Real	L/C	L/M	Ø Mango	€
F0663	3	3,18	9,53	31,75	8	18,05
F0664	4	3,97	9,53	31,75	8	19,76
F0665	5	4,76	12,70	31,75	8	20,88
F0666	6	6,35	19,05	31,75	8	23,18

**FRESAS PARA RANURAR DOS LABIOS
SERIE LARGA, REF. F002**

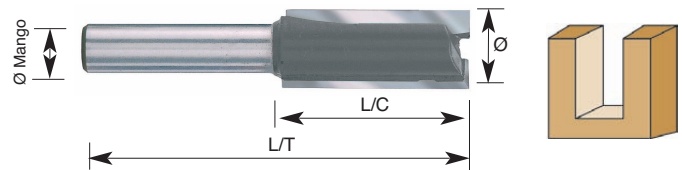

Referencia	Ø	Ø Real	L/C	L/T	Ø Mango	€
F00266	6	6,00	25	60	6	6,33
F0028	8	8,00	30	60	8	6,77
F00210	10	10,00	30	60	8	6,77
F00212	12	12,00	30	60	8	8,99
F00215	15	15,00	30	60	8	8,99
F00216	16	16,00	30	60	8	8,99

**FRESAS PARA RANURAR DOS LABIOS
REF. F001**

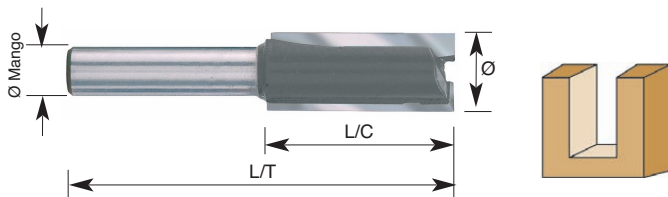

Referencia	Ø	Ø Real	L/C	L/T	Ø Mango	€
F0013	3	3,00	8	45	8	5,19
F0014	4	4,00	10	45	8	5,19
F0015	5	5,00	12	50	8	5,19
F00166	6	6,00	16	50	6	6,33
F0016	6	6,00	16	50	8	6,33
F0018	8	8,00	19	50	8	6,33
F0019	9	9,00	19	50	8	6,33
F00110	10	10,00	19	50	8	6,33
F00112	12	12,00	19	50	8	6,77
F00113	13	12,70	19	50	8	6,77
F00114	14	14,00	19	50	8	6,77
F00115	15	15,00	19	50	8	6,77
F00116	16	16,00	19	50	8	8,64
F00118	18	18,00	19	50	8	8,64
F00120	20	20,00	19	50	8	8,64
F00122	22	22,00	19	50	8	10,44
F00124	24	24,00	19	50	8	10,44
F00125	25	25,00	19	50	8	11,58

**FRESAS PARA RANURAR DOS LABIOS
CORTE AL CENTRO, REF. F003**

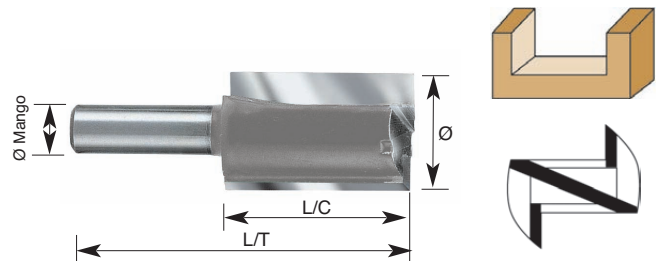

Referencia	Ø	Ø Real	L/C	L/T	Ø Mango	€
F00310	10	10,00	19	50	8	6,33
F00312	12	12,00	19	50	8	6,77

**FRESAS PARA RANURAR (BISAGRAS)
REF. F004**

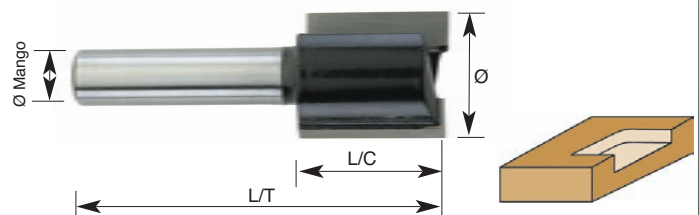

Referencia	Ø	Ø Real	L/C	L/T	Ø Mango	€
F00413	13	12,70	19	47	8	7,78
F00416	16	16,00	19	47	8	8,92
F00419	19	19,00	19	47	8	10,07

**FRESAS RECTAS PARA REFUNDIR CON
RODAMIENTO, REF. F005**

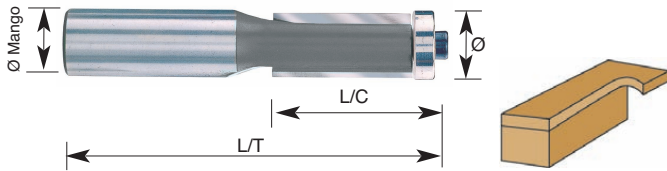

Referencia	Ø	Ø Real	L/C	L/T	Ø Mango	Rod	€
F00595	9,5	9,50	25	67	8	9,5 (3/8")	7,41
F00513	13	12,70	25	67	8	13	7,41
F00519	19	19,00	16	49	8	19	8,06

**FRESAS DOS LABIOS PARA BISELAR
CON RODAMIENTO, REF. F008**

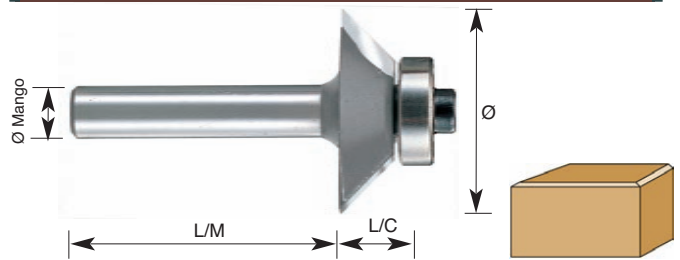

Referencia	Ø	Ø Real	L/C	L/M	Ø Mango	R	Rod	€
F00818	18	18,26	9,53	31,75	8	15	13	12,02
F00822	22	22,23	9,53	31,75	8	25	13	12,69
F00824	24	24,21	9,53	31,75	8	30	13	13,94
F00825	25	25,40	9,53	31,75	8	45	13	13,94

**FRESA PARA REFUNDIR Y RANURAR EN
V CON RODAMIENTO, REF. F006**

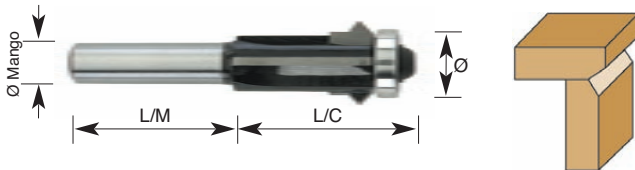

Referencia	Ø	Ø Real	L/C	L/M	Ø Mango	Rod	€
F00613	13	12,70	25,40	31,75	8	13	12,22

**FRESAS CUATRO LABIOS PARA
BISELAR CON RODAMIENTO, REF. F009**

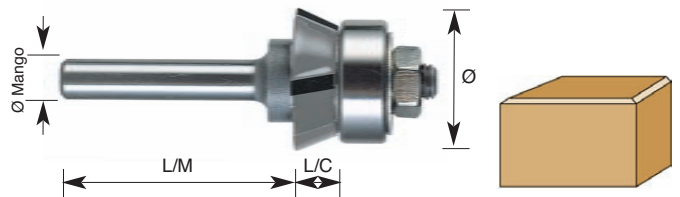

Referencia	Ø	Ø Real	L/C	L/M	Ø Mango	R	Rod	€
F00919	19	19,05	12,70	38,10	8	15	19	22,59

**FRESAS MIXTAS PARA REFUNDIR
Y BISELAR, REF. F007**

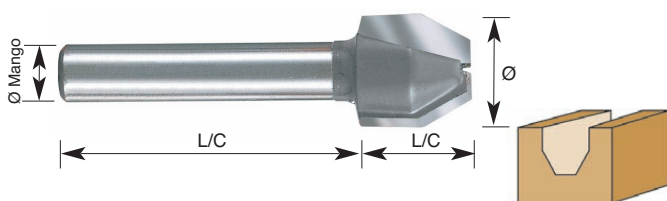

Referencia	Ø	Ø Real	L/C	L/M	Ø Mango	Rod	€
F0071322	13	12,70	12,70	31,75	8	22	7,78
F0071330	13	12,70	12,70	31,75	8	30	7,78
F0071345	13	12,70	12,70	31,75	8	45	7,78

**FRESAS DOS LABIOS PARA RANURAR
EN V, REF. F010**

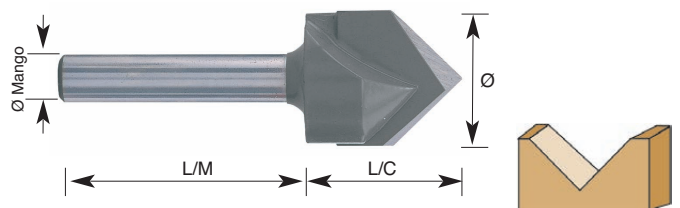

Referencia	Ø	Ø Real	L/C	L/M	Ø Mango	R	€
F010690	6	6,00	8,00	38,00	8	90	8,64
F0101390	13	12,70	12,70	45,00	8	90	10,51
F0101590	15	15,00	16,00	45,00	8	90	11,72

FRESAS DOS LABIOS PARA RANURAR EN V, 60°, REF. F068

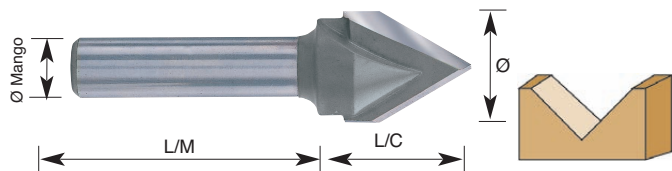

Referencia	Ø	Ø Real	L/C	L/M	Ø Mango	R	€
F0681360	13	12,70	16	31,75	8	60	12,20

FRESAS DE RADIO CONVEXO REF. F013

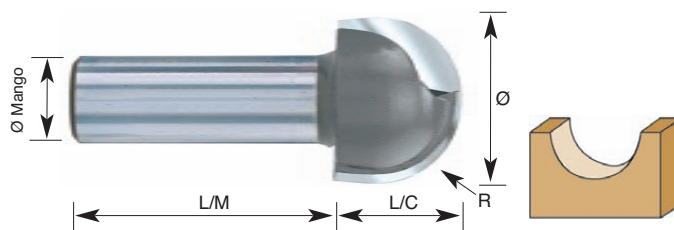

Referencia	Ø	Ø Real	L/C	L/M	Ø Mango	R	€
F0136	6	6,00	6,50	51	8	3,00	8,13
F01395	9,5	9,50	6,50	51	8	4,75	9,57
F01313	13	12,70	9,50	51	8	6,35	11,16
F01316	16	16,00	9,50	51	8	8,00	13,31
F01319	19	19,00	11,50	51	8	9,50	16,11

FRESAS DOS LABIOS PARA RANURAR EN V CON RODAMIENTO, REF. F011

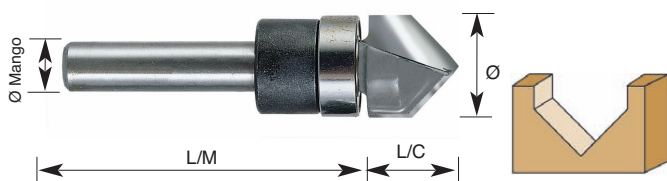

Referencia	Ø	Ø Real	L/C	L/M	Ø Mango	R	Rod	€
F01113	13	12,70	12,70	38,10	8	90	12	16,52

FRESAS PARA PERFILAR REF. F014

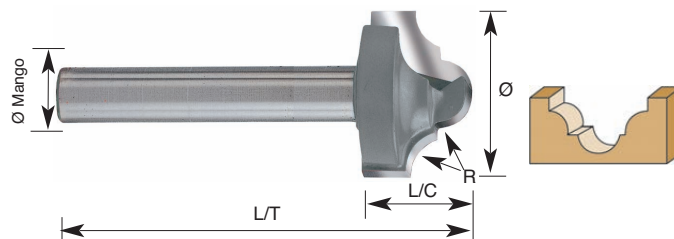

Referencia	Ø	Ø Real	L/C	L/T	Ø Mango	R	€
F01419	19	19,00	13	45	8	4	18,56

FRESAS PARA ENSAMBLAR (COLA MILANO) DOS LABIOS, REF. F012

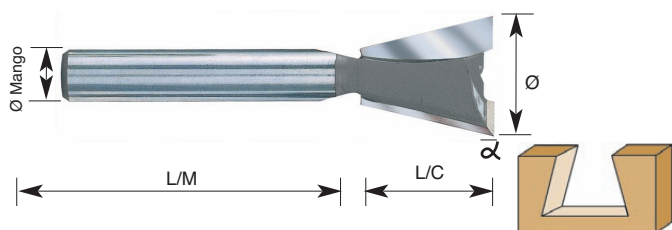

Referencia	Ø	Ø Real	L/C	L/M	Ø Mango	α	€
F01295	9,5	9,50	9,50	41	8	9	5,84
F01213	13	12,70	12,70	41	8	14	5,98
F01218	18	18,00	16,00	45	8	14	6,70

FRESAS PARA PERFILAR CON RODAMIENTO DE PROTECCIÓN DOBLE, REF. F015

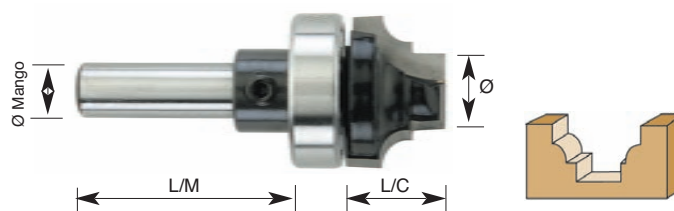

Referencia	Ø	Ø Real	L/C	L/M	Ø Mang.	R	Rod	€
F01522	22	22,23	12,70	38,10	8	4,00	22	18,05
F01535	35	35,00	14,29	50,80	8	6,35	35 (1-3/8")	29,36

FRESAS PARA TALADRAR Y REFUNDIR, REF. F016

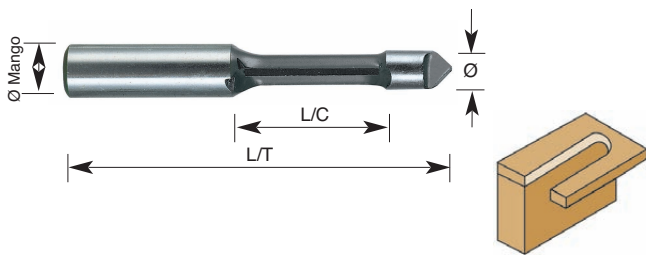

Referencia	Ø	Ø Real	L/C	L/T	Ø Mango	€
F01666	6	6,00	19	62	6	8,13
F0168	8	8,00	20	62	8	8,64

FRESAS RADIO CÓNCAVO PARA REDONDEAR CANTOS, REF. F019

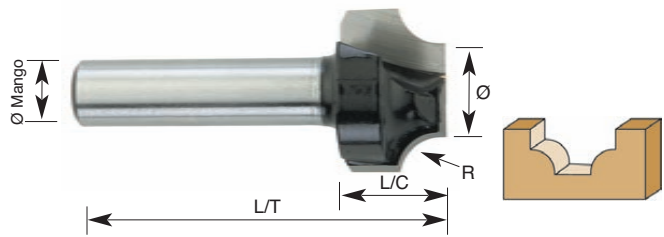

Referencia	Ø	Ø Real	L/C	L/T	Ø Mango	R	€
F01919	19	19,00	12	44	8	4	12,59
F01921	21	21,00	12	44	8	5	13,75
F01923	23	23,00	12	44	8	6	13,75

FRESAS PARA CERRADURAS, REF. F017

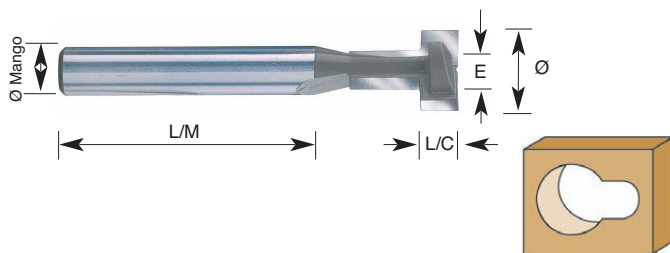

Referencia	Ø	Ø Real	L/C	L/M	Ø Mango	Ø E	€
F01795	9,50	9,50	4,76	31,75	8	4,76	10,19

FRESAS RADIO CÓNCAVO PARA REDONDEAR CANTOS CON RODAMIENTO, REF. F020

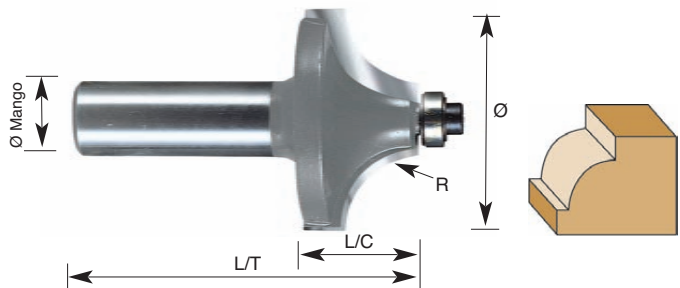

Referencia	Ø	Ø Real	L/C	L/T	Ø Mango	R	Rod	€
F02016	16	16,00	12,70	48	8	1,60	9,5 (3/8")	12,30
F02019	19	19,00	12,70	48	8	3,20	9,5 (3/8")	13,59
F02022	22	22,20	12,70	48	8	4,80	9,5 (3/8")	13,75
F02025	25	25,40	12,70	48	8	6,40	9,5 (3/8")	15,25
F02028	28	28,50	12,70	48	8	8,00	9,5 (3/8")	15,97
F02032	32	32,00	16,00	52	8	10,00	9,5 (3/8")	18,28
F02038	38	38,00	19,00	55	8	12,70	9,5 (3/8")	20,36

FRESAS PUNTA BOLA, REF. F018

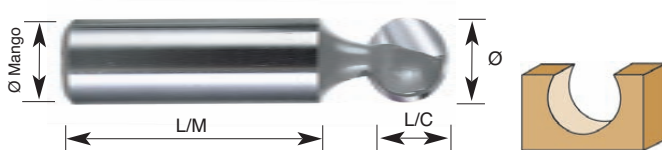

Referencia	Ø	Ø Real	L/C	L/M	Ø Mango	€
F01813	13	12,70	12,70	31,75	8	14,15
F01819	19	19,05	19,05	31,75	8	18,93

FRESAS PARA CANTEAR, REF. F021

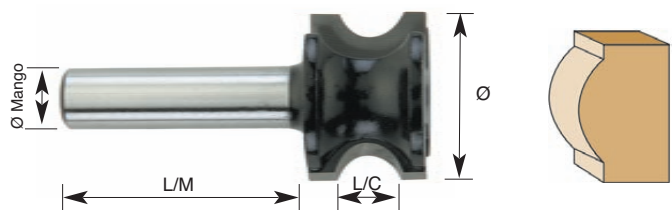

Referencia	Ø	Ø Real	L/C	L/M	Ø Mango	E	€
F021228	22	22,23	7,94	31,75	8	3,20	14,15
F0212295	22	22,23	9,53	31,75	8	3,20	15,62
F0212213	22	22,23	12,70	31,75	8	3,20	17,10
F0212416	24	23,81	15,88	31,75	8	4,00	18,56

FRESAS SEMICIRCULARES, REF. F022

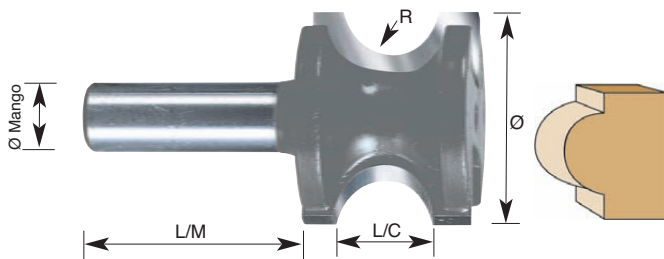

Referencia	Ø	Ø Real	L/C	L/M	Ø Mango	R	€
F02222	22	22,23	6,35	31,75	8	3,20	17,54
F02225	25	25,40	9,53	31,75	8	4,75	26,28
F02229	29	28,58	12,70	31,75	8	6,35	32,73

**FRESAS PARA REBAJES
CON RODAMIENTO, REF. F025**

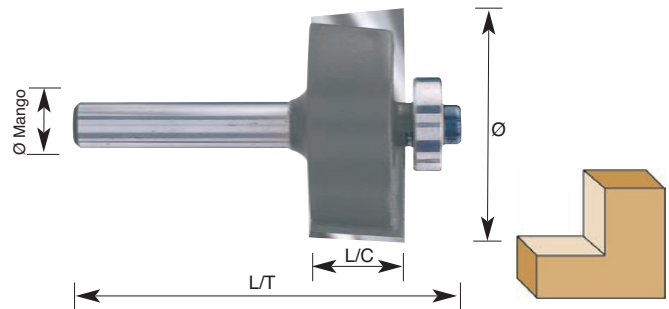

Referencia	Ø	Ø Real	L/C	L/M	Ø Mango	R	Rod	€
F02532	32	32,00	12,70	49	8	9,50	13	15,25

**FRESAS PARA BISELAR
CON RODAMIENTO, REF. F023**

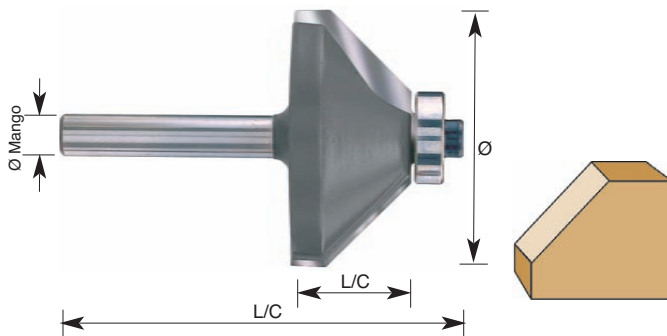

Referencia	Ø	Ø Real	L/C	L/T	Ø Mango	α	Rod	€
F02319	19	19,00	12,70	48	8	25	13	17,11
F02325	25	25,40	9,50	46	8	45	13	19,28
F02330	30	30,00	13,00	50	8	45	13	20,71
F02342	42	42,00	18,00	54	8	45	13	23,60

**FRESAS DE RADIO CONVEXO
CON RODAMIENTO, REF. F026**

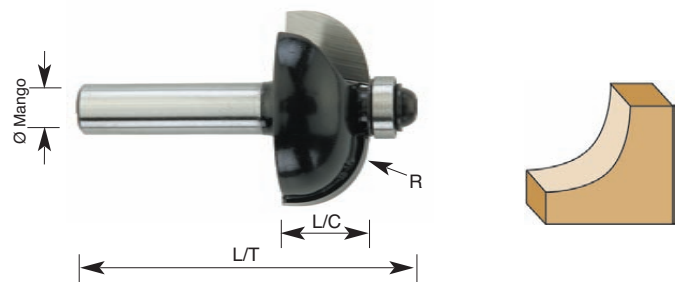

Referencia	Ø	Ø Real	L/C	L/T	Ø Mango	R	Rod	€
F02622	22	22,00	12,70	47	8	6,00	9,5 (3/8")	17,41
F02629	29	28,60	12,70	47	8	9,50	9,5 (3/8")	22,08
F02630	30	30,00	16,00	51	8	10,00	9,5 (3/8")	23,23
F02635	35	35,00	16,00	51	8	12,70	9,5 (3/8")	25,75

**FRESAS PARA REBAJES
CON RODAMIENTO, REF. F024**

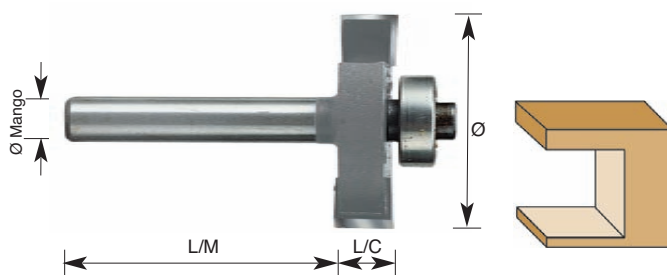

Referencia	Ø	Ø Real	L/C	L/M	Ø Mango	Rod	€
F02432	32	31,75	12,70	31,75	8	13	16,36

**FRESAS PARA PERFILAR
CON RODAMIENTO, REF. F027**

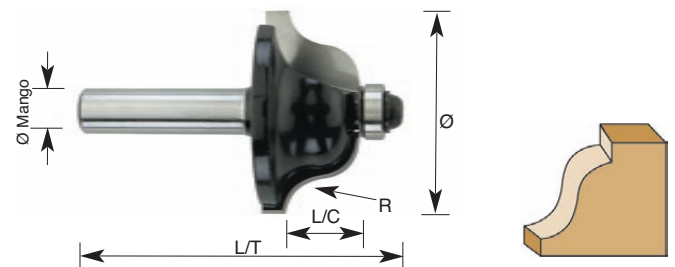

Referencia	Ø	Ø Real	L/C	L/T	Ø Mango	R	Rod	€
F02725	25	25,40	13	48	8	4,00	9,5 (3/8")	21,29
F02735	35	35,00	19	55	8	6,35	9,5 (3/8")	23,02

FRESAS PARA PERFILAR CON RODAMIENTO, REF. F067

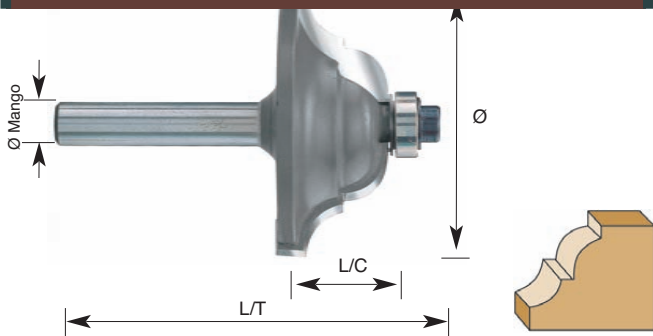

Referencia	Ø	Ø Real	L/C	L/T	Ø Mango	R	Rod	€
F067285	28,5	28,50	13	51	8	4,00	9,5 (3/8")	29,64
F06738	38	38,00	19	57	8	6,35	9,5 (3/8")	35,46

FRESAS PARA PERFILAR CON RODAMIENTO, REF. F030

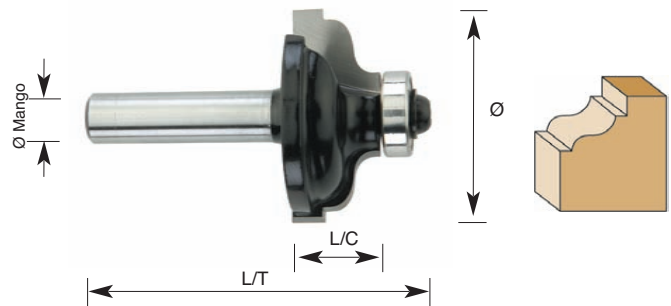

Referencia	Ø	Ø Real	L/C	L/T	Ø Mango	R - r	Rod	€
F03032	32	32,50	13	51	8	4,8-3,6	9,5 (3/8")	30,21

FRESAS PARA PERFILAR CON RODAMIENTO, REF. F028

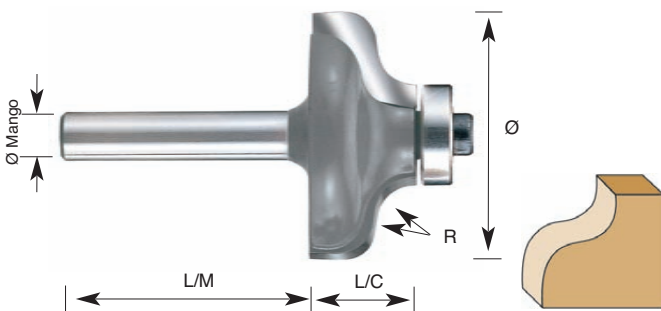

Referencia	Ø	Ø Real	L/C	L/M	Ø Mango	R	Rod	€
F02832	32	31,75	12,70	31,75	8	4,75	13	29,20
F02838	38	38,10	15,88	31,75	8	6,35	13	32,80

FRESAS PARA PERFILAR CON RODAMIENTO, REF. F031

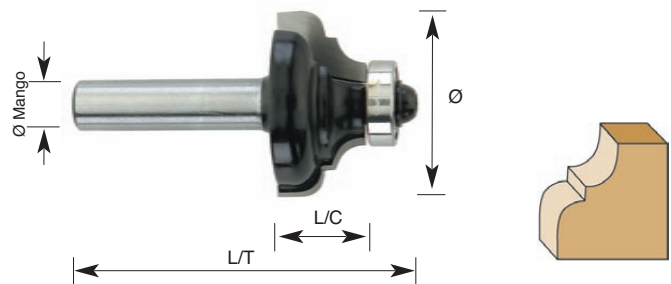

Referencia	Ø	Ø Real	L/C	L/T	Ø Mango	R - r	Rod	€
F03129	29	28,70	13,00	52	8	4-4	13	29,64
F03135	35	35,00	17,50	56	8	6,35-4,80	13	33,17

FRESAS PARA PERFILAR CON RODAMIENTO, REF. F029

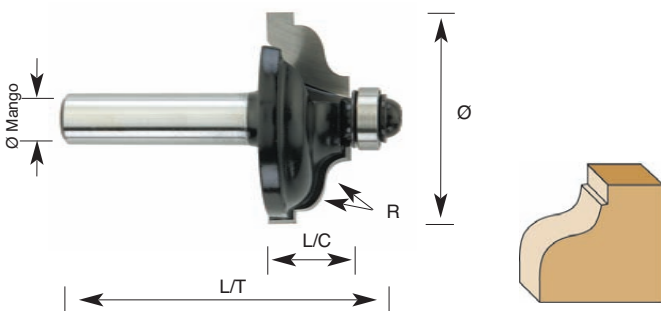

Referencia	Ø	Ø Real	L/C	L/T	Ø Mango	R - r	Rod	€
F02932	32	32,50	13	52	8	4,8-3,6	13	30,21

FRESAS PARA PERFILAR CON RODAMIENTO, REF. F032

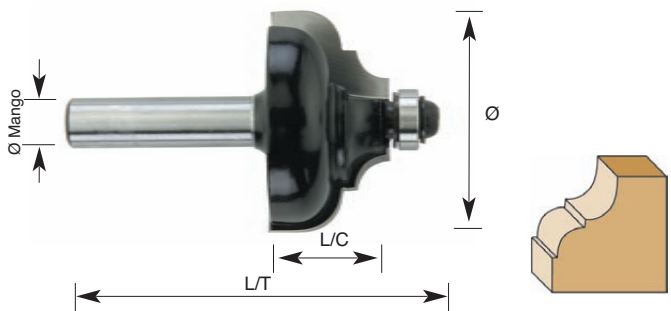

Referencia	Ø	Ø Real	L/C	L/M	Ø Mango	R - r	Rod	€
F03228	28	28,40	13,00	31,75	8	4-4	9,5 (3/8")	29,64
F03235	35	35,00	17,50	31,75	8	6,35-4,80	9,5 (3/8")	33,17

**FRESAS DE RADIO CONVEXO
CON RODAMIENTO, REF. F033**

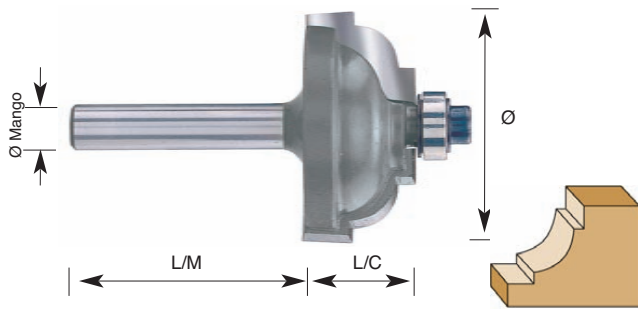

Referencia	Ø	Ø Real	L/C	L/M	Ø Mango	R	Rod	€
F03325	25	25,40	12,70	31,75	8	4,75	9,5 (3/8")	25,17
F03329	29	28,58	14,29	31,75	8	6,35	9,5 (3/8")	25,91
F03332	32	31,75	15,88	31,75	8	8,00	9,5 (3/8")	26,63

**FRESAS PARA RANURAS CÓNCAVAS
CON DOBLE RODAMIENTO, REF. F036**

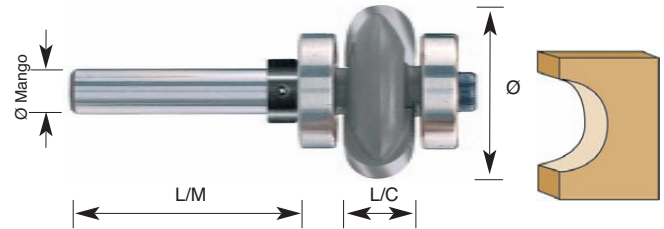

Referencia	Ø	Ø Real	L/C	L/M	Ø Mango	R	Rod	€
F03622	22	22,23	6,35	31,75	8	3,20	16	15,53
F03625	25	25,40	9,53	31,75	8	4,75	16	18,65

**FRESAS SEMICIRCULARES
CON RODAMIENTO, REF. F034**

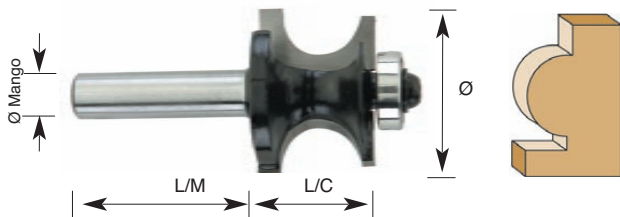

Referencia	Ø	Ø Real	L/C	L/M	Ø Mango	R	Rod	€
F03422	22	22,23	14,29	31,75	8	3,20	13	33,24
F03425	25	25,40	17,46	31,75	8	4,75	13	37,64
F03429	29	28,58	19,05	31,75	8	6,35	13	41,04

**FRESAS PARA MOLDURAS
CON RODAMIENTO, REF. F037**

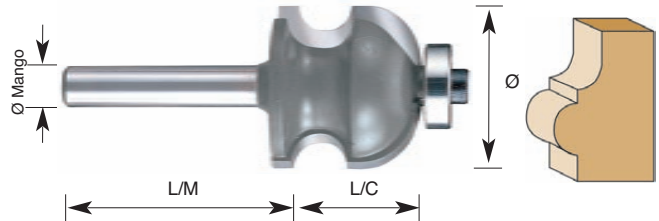

Referencia	Ø	Ø Real	L/C	L/M	Ø Mango	R	Rod	€
F03732	32	31,75	36,51	31,75	8	9,50	13	28,92

**FRESAS PARA REDONDEAR CANTOS
CON DOBLE RODAMIENTO, REF. F035**

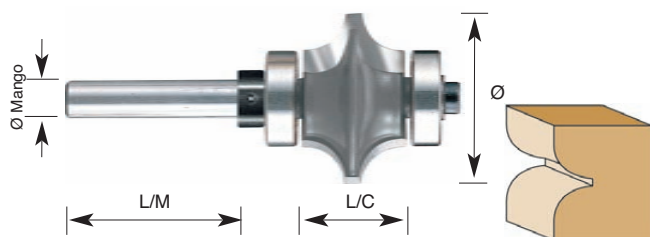

Referencia	Ø	Ø Real	L/C	L/M	Ø Mango	R	Rod	€
F03522	22	22,23	9,53	31,75	8	3,20	16	18,91
F03525	25	25,40	12,70	31,75	8	4,75	16	21,87

FRESAS PARA MOLDURAS, REF. F038

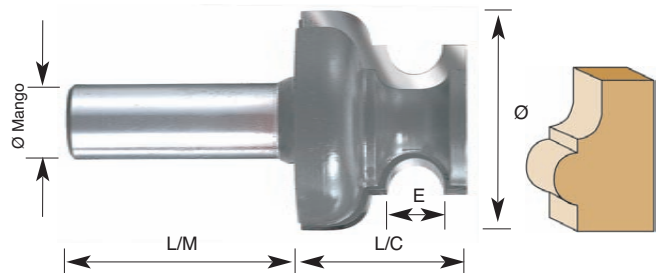

Referencia	Ø	Ø Real	L/C	L/M	Ø Mango	E	€
F03835	35	34,93	28,58	38,10	8	9,50	31,60

FRESAS PARA BISAGRA, REF. F039

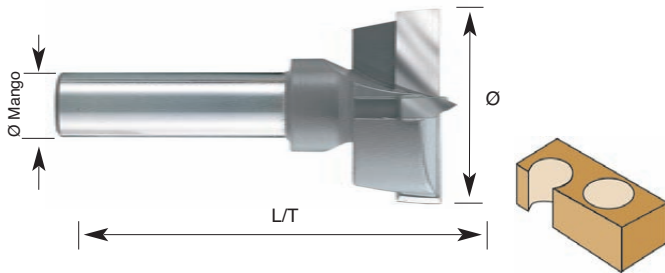

Referencia	Ø	Ø Real	L/C	L/T	Ø Mango	€
F03925	25	25,40	-	76,20	8	24,07
F03935	35	34,93	-	76,20	8	26,93

FRESAS PARA MOLDURAS CON RODAMIENTO, REF. F042

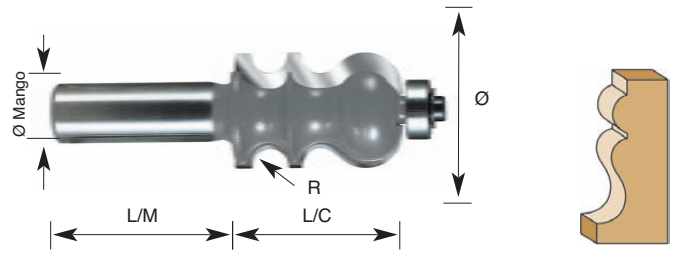

Referencia	Ø	Ø Real	L/C	L/M	Ø Mango	R	Rod	€
F04217	17	17,46	25,40	31,75	8	3,20	13	24,23
F04224	24	23,81	34,93	38,10	8	4,00	13	30,15

FRESAS PARA PASAMANOS CON RODAMIENTO, REF. F040

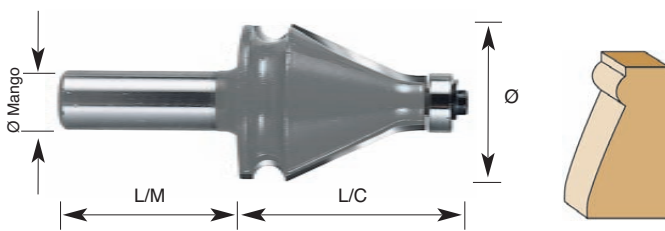

Referencia	Ø	Ø Real	L/C	L/M	Ø Mango	R	Rod	€
F04035	35	34,93	38,10	38,10	8	3,20	13	35,09

FRESAS PARA MOLDURAS CON RODAMIENTO, REF. F043

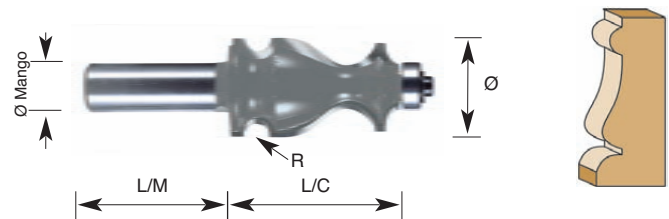

Referencia	Ø	Ø Real	L/C	L/M	Ø Mango	R	Rod	€
F04319	19	19,05	25,40	31,75	8	8,00	13	24,23
F04327	27	26,99	41,28	38,10	8	3,20	13	30,15

FRESAS PARA PLAFONES, REF. F041

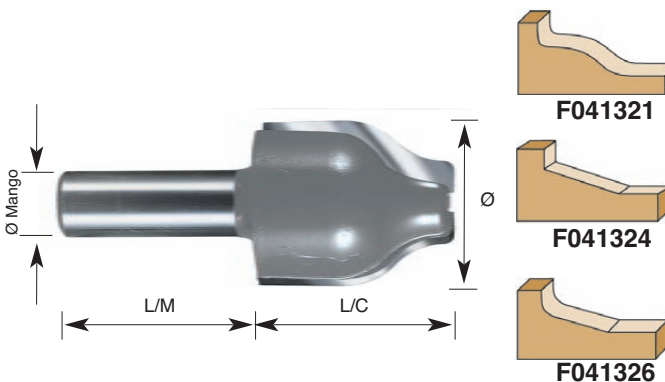

Referencia	Ø	Ø Real	L/C	L/M	Ø Mango	€
F041321	32	31,75	38,10	38,10	8	36,18
F041324	32	31,75	38,10	38,10	8	36,18
F041326	32	31,75	38,10	38,10	8	36,18

FRESAS PARA MOLDURAS CON RODAMIENTO, REF. F044

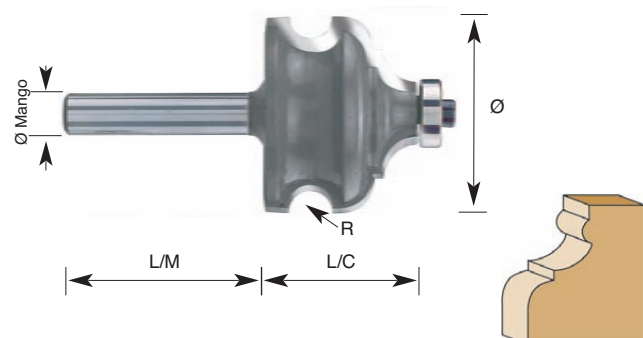

Referencia	Ø	Ø Real	L/C	L/M	Ø Mango	R	Rod	€
F04444	44	44,45	28,58	44,45	12	3,20	13	30,31

FRESAS PARA PERFILES Y TIRADORES, REF. F045

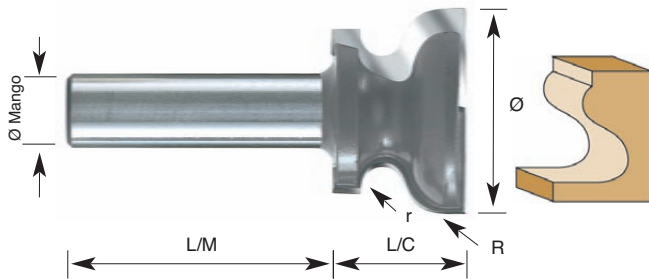

Referencia	Ø	Ø Real	L/C	L/M	Ø Mango	R - r	€
F04535	35	34,93	22,23	31,75	8	7,00-6,35	25,03

FRESAS PARA PERFILES Y TIRADORES, REF. F046

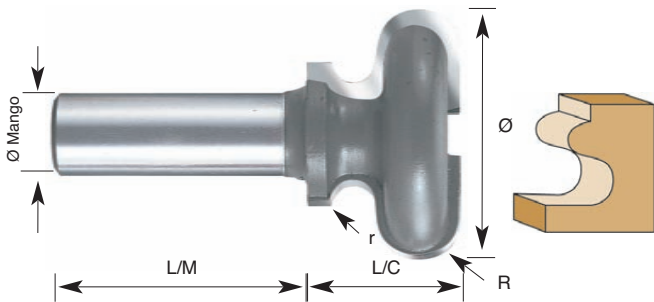

Referencia	Ø	Ø Real	L/C	L/M	Ø Mango	R - r	€
F04644	44	44,45	28,58	38,10	12	12,70-3,20	47,84

FRESAS PARA CAJONES, REF. F047

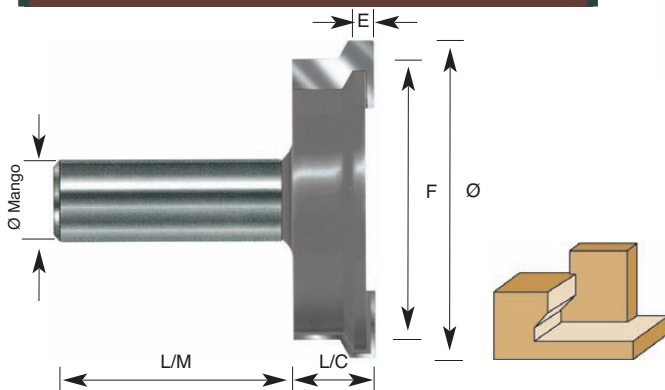

Referencia	Ø	Ø Real	L/C	L/M	Ø Mango	E	F	€
F04725	25	25,40	12,70	38,10	8	4	19,00	13,71
F04751	51	50,80	12,70	38,10	12	4	44,50	29,10

FRESAS MULTI PERFILES CON RODAMIENTO, REF. F048

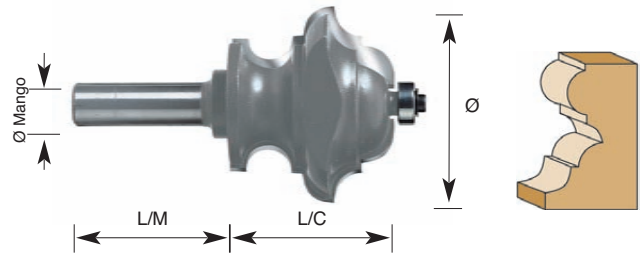

Referencia	Ø	Ø Real	L/C	L/M	Ø Mango	Rod	€
F04832	32	31,75	25,40	31,75	8	13	28,50
F04857	57	57,15	47,63	44,45	12	13	100,00

FRESAS PARA MOLDURAS REF. F049

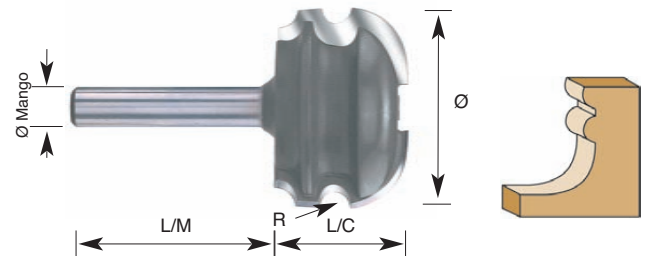

Referencia	Ø	Ø Real	L/C	L/M	Ø Mango	R	€
F04932	32	31,75	20,64	38,10	8	4,75	25,54

FRESAS PARA PLAFONES CON RODAMIENTO, REF. F050

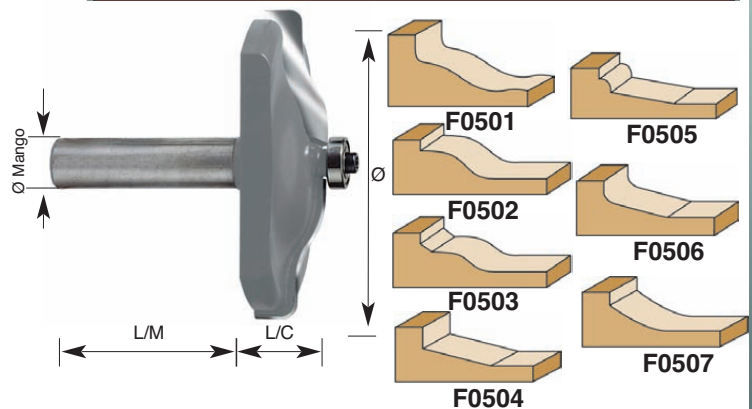

Referencia	Ø	Ø Real	L/C	L/M	Ø Mango	Rod	€
F0501	76	76,20	15,88	50,80	12	13	53,80
F0502	76	76,20	15,88	50,80	12	13	53,80
F0503	76	76,20	15,88	50,80	12	13	53,80
F0504	76	76,20	15,88	50,80	12	13	53,80
F0505	76	76,20	15,88	50,80	12	13	53,80
F0506	76	76,20	15,88	50,80	12	13	53,80
F0507	76	76,20	15,88	50,80	12	13	53,80

**FRESAS PARA RANURAR 2 DIENTES
DE CORTE SIN HUSILLO, REF. F051**

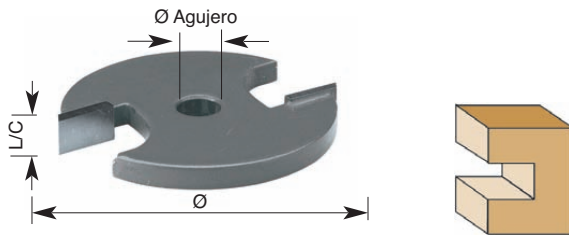

Referencia	Ø	Ø Real	L/C	Ø Agujero	€
F051238	48	47,63	2,38	7,94	10,10
F051318	48	47,63	3,18	7,94	10,10
F051397	48	47,63	3,97	7,94	10,10
F051475	48	47,63	4,75	7,94	10,10
F051635	48	47,63	6,35	7,94	10,10

**HUSILLO CON RODAMIENTO
REF. F054**

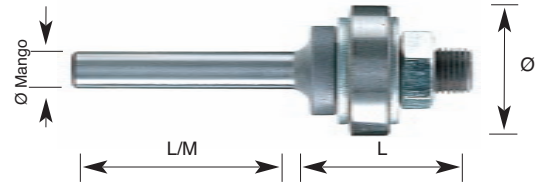

Referencia	Ø Agujero	Ø Real	L	L/M	Ø Mango	€
F0546	8	7,94	23,81	31,75	6	11,12
F0548	8	7,94	23,81	31,75	8	11,12
F054127	8	7,94	23,81	38,10	12	11,12

**FRESAS PARA RANURAR 3 DIENTES
DE CORTE SIN HUSILLO, REF. F052**

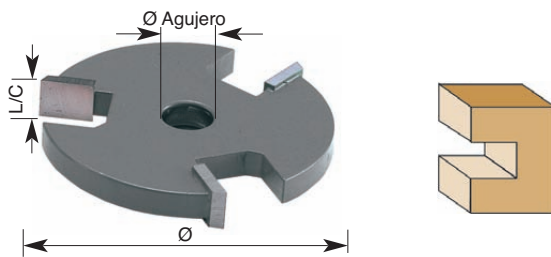

Referencia	Ø	Ø Real	L/C	Ø Agujero	€
F052238	48	47,63	2,38	7,94	12,08
F052318	48	47,63	3,18	7,94	12,08
F052397	48	47,63	3,97	7,94	13,31
F052475	48	47,63	4,75	7,94	13,31
F052635	48	47,63	6,35	7,94	13,31

**FRESAS PARA MACHIEMBRAR
CON RODAMIENTO, REF. F055**

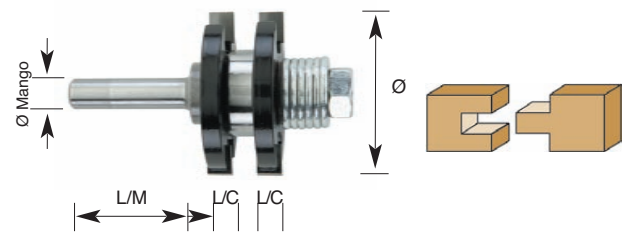

Referencia	Ø	Ø Real	L/C	L/M	Ø Mango	Rod	€
F05541	41	41,28	6,35	31,75	8	22	30,19

**FRESAS PARA RANURAR 4 DIENTES
DE CORTE SIN HUSILLO, REF. F053**

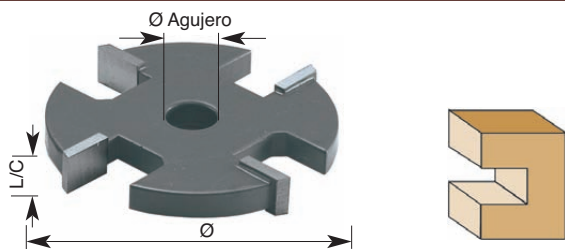

Referencia	Ø	Ø Real	L/C	Ø Agujero	€
F053238	51	50,80	2,38	7,94	12,85
F053318	51	50,80	3,18	7,94	12,85
F053397	51	50,80	3,97	7,94	14,47
F053475	51	50,80	4,75	7,94	14,47
F053635	51	50,80	6,35	7,94	14,47

**CONJUNTO DE 6 FRESAS
PARA ENSAMBLAR, REF. F056**

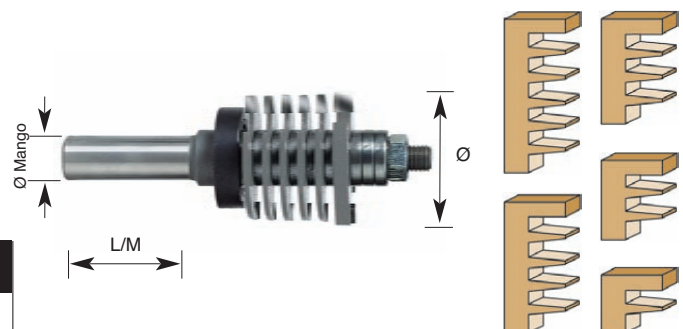

Referencia	Ø	Ø Real	L/C	L/M	Ø Mango	Rod	€
F05638	38	38,00	40,08	38,10	8	28	118,28

**FRESAS PARA MACHIEMBRAR
REF. F057**

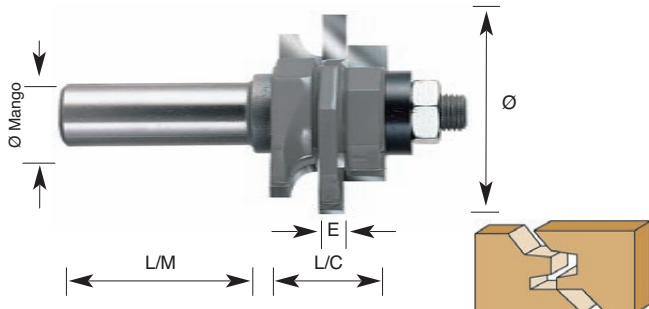

Referencia	Ø	Ø Real	L/C	L/M	Ø Mango	E	€
F05745	45	45,24	19,05	38,10	8	4,76	55,10

**FRESAS PARA MACHIEMBRAR
REF. F060**

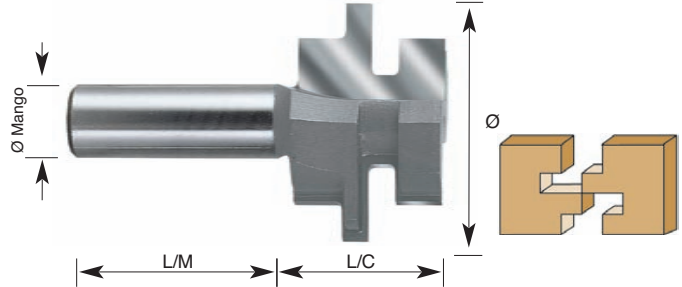

Referencia	Ø	Ø Real	L/C	L/M	Ø Mango	€
F06030	30	30,16	25,40	31,75	8	20,67

**FRESAS PARA JUNTAS DE 45°
REF. F058**

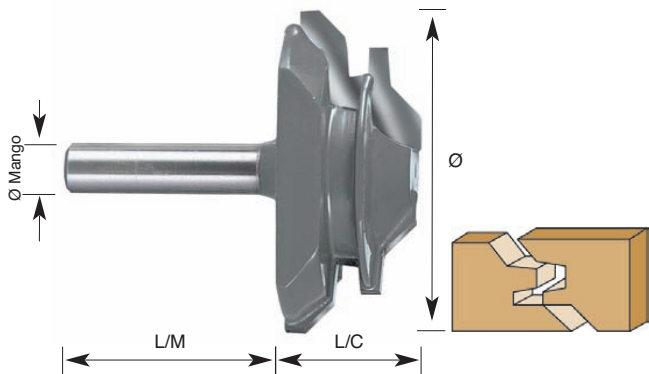

Referencia	Ø	Ø Real	L/C	L/M	Ø Mango	€
F05844	44	44,45	19,05	38,10	8	36,71
F05851	51	50,80	22,23	38,10	12	53,59
F05870	70	69,85	30,16	44,45	12	87,35

**JUEGO DE 2 FRESAS
PARA MACHIEMBRAR, REF. F061**

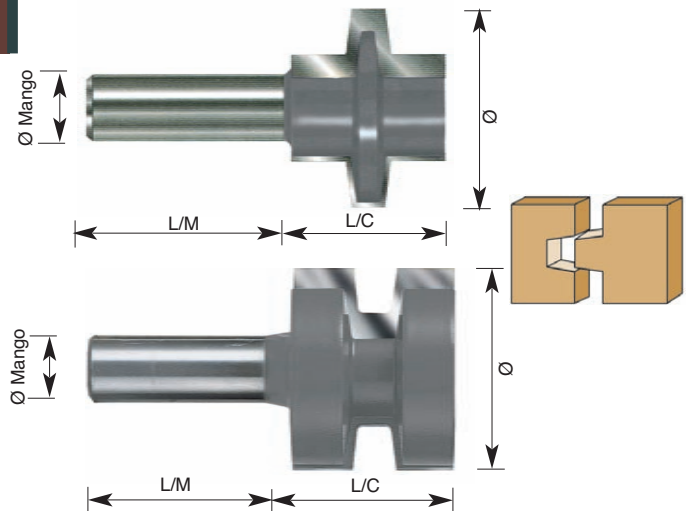

Referencia	Ø	Ø Real	L/C	L/M	Ø Mango	€
F06138	38	38,10	28,58	31,80	8	34,80

**FRESAS PARA MACHIEMBRAR
REF. F059**

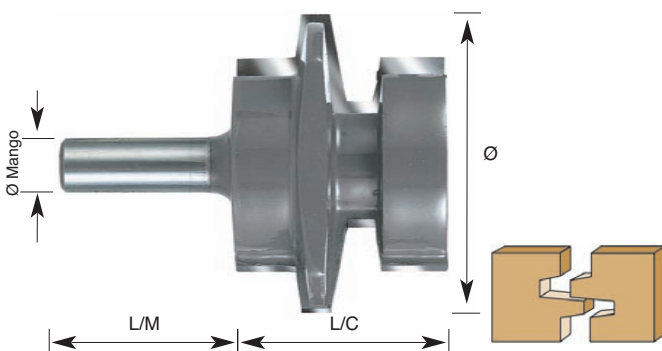

Referencia	Ø	Ø Real	L/C	L/M	Ø Mango	€
F05941	41	41,28	25,40	44,45	8	29,80

**JUEGO DE 2 FRESAS
PARA MACHIEMBRAR, REF. F062**

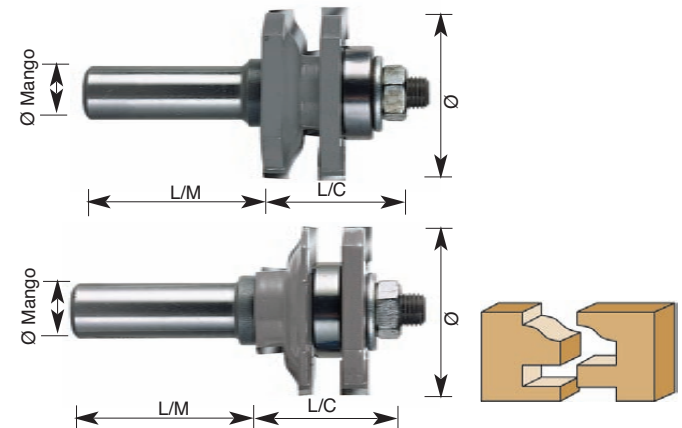

Referencia	Ø	Ø Real	L/C	L/M	Ø Mango	Rod	€
F06241	41	41,28	25,40	38,10	8	22	78,69

JUEGO DE 2 FRESAS PARA MACHIEMBRAR, REF. F063

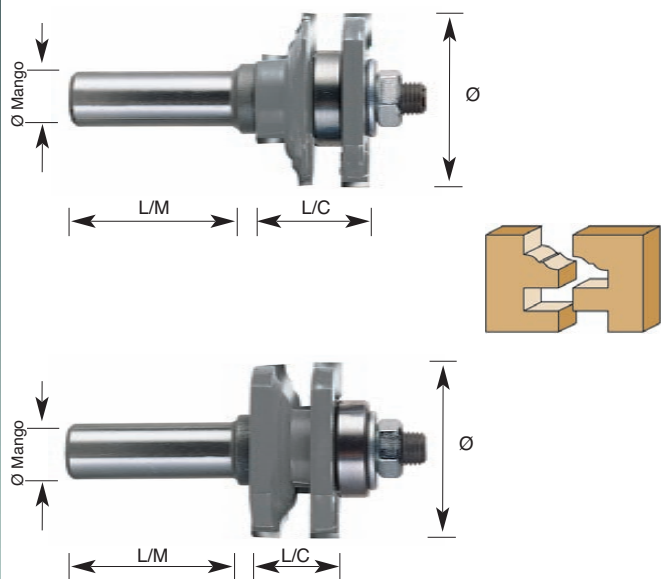

Referencia	Ø	Ø Real	L/C	L/M	Ø Mango	Rod	€
F06341	41	41,28	25,40	38,10	8	22	78,69

JUEGO DE 2 FRESAS PARA MACHIEMBRAR, REF. F065

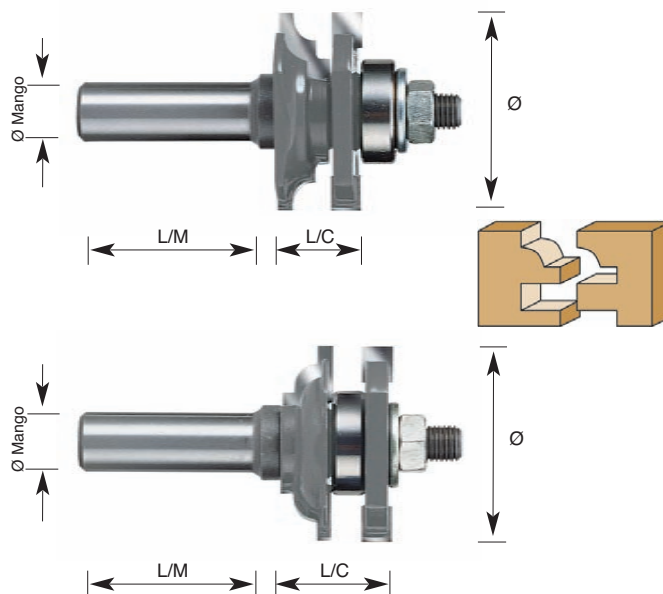

Referencia	Ø	Ø Real	L/C	L/M	Ø Mango	Rod	€
F06541	41	41,28	25,40	38,10	8	22	78,69

JUEGO DE 2 FRESAS PARA MACHIEMBRAR, REF. F064

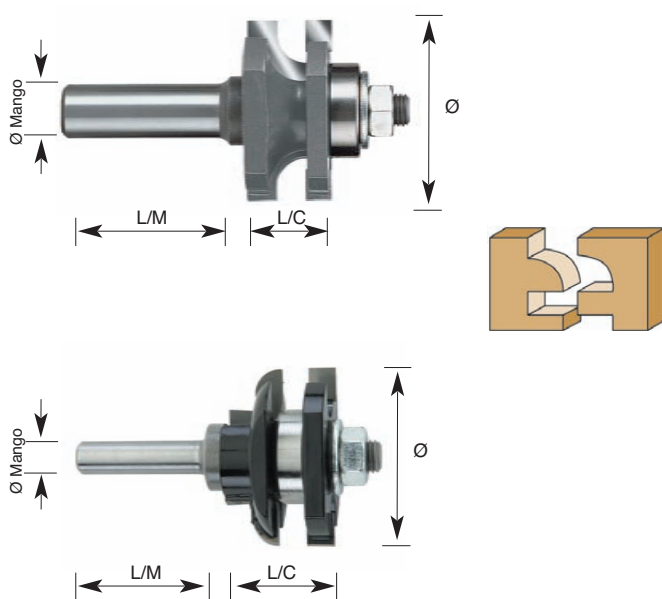

Referencia	Ø	Ø Real	L/C	L/M	Ø Mango	Rod	€
F06441	41	41,28	25,40	38,10	8	22	78,69

RODAMIENTOS



Referencia	Ø Exterior	Ø Interior	€
RM63	6	3	3,08
RM104	10	4	3,08
RM124	12	4	3,08
RM135	13	5	3,08
RM165	16	5	5,73
RM196	19	6	5,73
RM228	22	8	5,73
RM248	24	8	7,58

REDUCTORES DE MANGO



Referencia	Ø Exterior	Ø Interior	€
RD86	8	6	6,17
RD1276	12,70	6	6,17
RD1278	12,70	8	6,17

**JUEGO DE FRESAS, SERIE ECONÓMICA
(ESCUELAS F.P.)**

Composición KIT 24 PIEZAS

Tipo de fresas	Ø	R
Fresa para ranurar dos labios	6,35	
Fresa para ranurar dos labios	9,50	
Fresa para ranurar dos labios	12,70	
Fresa para ranurar dos labios	19,00	
Fresa para visagras	12,70	
Fresa de radio convexo	6,35	
Fresa de radio convexo	12,70	
Fresa para ranurar en V	12,70	
Fresa para ensambles (cola milano)	9,50	
Fresa para ensambles (cola milano)	12,70	
Fresa para taladrar y refundir	6,35	
Fresa para rebajes con rodamiento	32,00	
Fresa para rebajes con rodamiento	32,00	
Fresa para perfilar con rodamiento		4,00
Fresa de radio convexo con rodamiento		6,35
Fresa de radio convexo con rodamiento		9,50
Fresa para redondear con rodamiento		3,00
Fresa para redondear con rodamiento		4,75
Fresa para redondear con rodamiento		6,35
Fresa para redondear con rodamiento		9,50
Fresa para biselar 7°	12,70	
Fresa recta para refundir con rodamiento	12,70	
Fresa 22° refundir y biselar c/rodam.	12,70	
Fresa para biselar 45° con rodamiento	30,00	

* Ø mango 8 mm.



P.V.P. 188 €